

FRAME PAD ASSEMBLY

FOR USE ON **14FT ROUND** TRAMPOLINE FRAMES

(If you own a 12ft Round Trampoline please refer to the other section of this manual)

LAY THE FRAME PAD OVER THE FRAME OF THE TRAMPOLINE

Lay the Frame Pad on the frame. Adjust the position of the Frame Pad so the notches are aligned with the trampoline legs as shown. (See picture below)

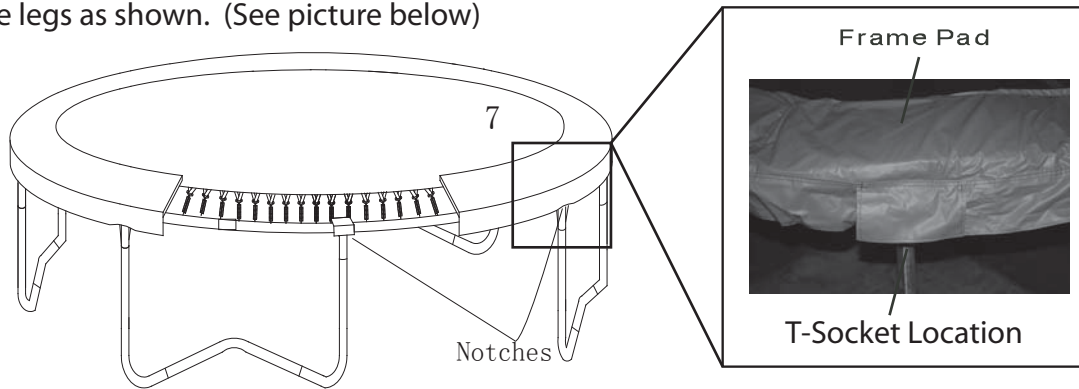

ASSEMBLE THE FRAME PAD IN THE CIRCULAR FORM

Once the frame pad is laid in the correct position on the frame, find the point at which the two ends of the pad connect together by the velcro. (see diagram 1). The pad will buckle together with the straps from the opposite sides in 3 locations as shown. (see diagram 2).

Diagram 1



Diagram 2

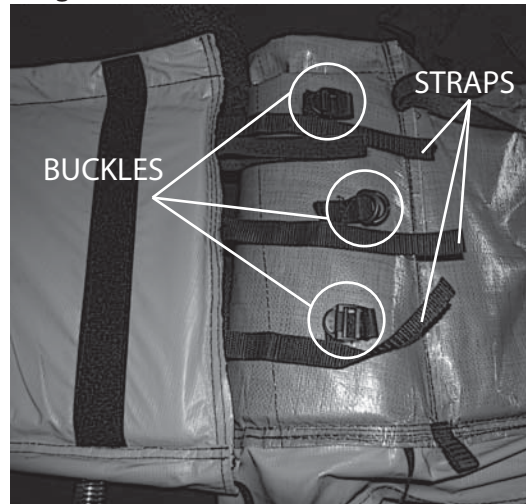

Next insert each strap into a buckle by following the steps below:



1 Straighten the strap so there are no kinks or twist in it.

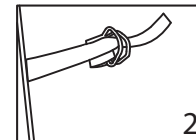

2 Insert the strap into both d-rings.

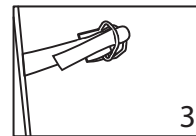

3 Wrap the strap back over the bottom ring and through the top ring. Be sure to keep the strap straight (see diagram 3)

Tighten all straps fully to secure them in place in the buckles (see diagram 4).

Diagram 3



Diagram 4



Diagram 5



Finally, tuck all the straps and buckles under the pad and secure the velcro in place. Straighten out the 4 black ties so they are lined up as shown (see diagram 5).

FRAME PAD ASSEMBLY CONTINUED
FOR USE ON 14FT ROUND TRAMPOLINE FRAMES

(If you own a 12ft Round Trampoline please refer to the other section of this manual)

Finally, secure the end of the two pad sides together by tying a know in the each of the two straps of black webbing (see below LEFT). These straps are located near the bed/jumping surface of the pad. REMEBER: Tuck the straps under the pad away from the trampoline bed/jumping surface (4). Also tie a know in the straps located near the frame of the trampoline (see below RIGHT).

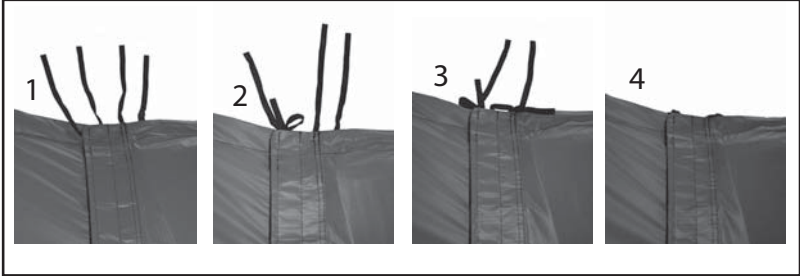

TIE TWO KNOTS NEAR BED/JUMPING SURFACE



TIE ONE KNOT NEAR FRAME TOPRAILS

SECURE THE FRAME PAD TO THE FRAME OF THE TRAMPOLINE

Make sure the frame pad is still positioned in the correct location on the frame of the trampoline. There will be two types of straps to secure the pad. Find a starting point and first circle the trampoline in a clockwise pattern attaching all the ELASTIC TIE DOWN STRAPS.

These attachments are located on the inner ring of the frame pad and should be tied into the v-ring closest to them. It will make this step easier if you tie the straps from the UNDER side of the trampoline. (see right)

ELASTIC TIE DOWN

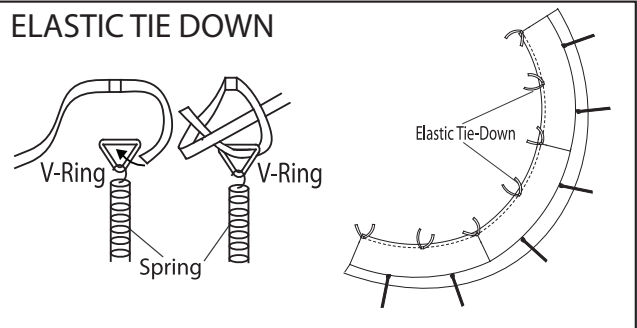

CORD LOCKS

Retrun to the starting location and again circle the trampoline in a clockwise pattern this time attaching all the CORD LOCK STRAPS. These attachments are located on the outer ring of the frame pad and should be wrapped around the top rail and looped through the v-ring closest to them. Follow the steps below for ALL the cord lock locations.

- Begin by threading the end of the cord lock with OUT the buckle throught the black webbing tab on the frame pad (1). Then loop the buckle through the free end of the cord (1).
- Next pull the buckle down as far as it will reach and tighten the loop into a knot at the webbing tab (2).
- Once the loop is tight, then wrap the cord around the OUTSIDE of the trampoline top rail, next to a spring, and into a v-ring nearest the cord. Be sure to enter the buckle through the TOP of the v-ring (3).
- Once the buckle has been pulled through the v-ring loop it around the ring back through the two sides of the cord (4).
- Finally pull up on the buckle to tighten the loop at the v-ring. Finish by pushing on the release of the buckle and pushing it all the way down until it touches the edge of the cord at the loop knot (5).

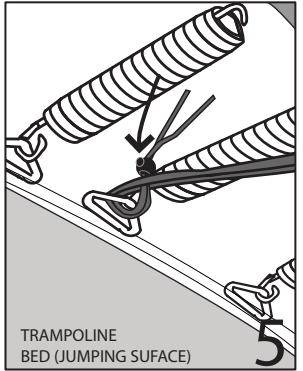
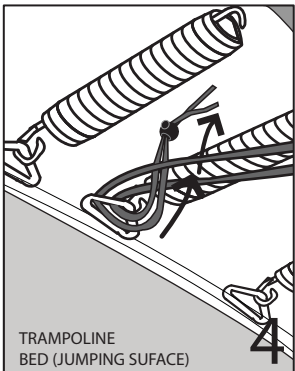
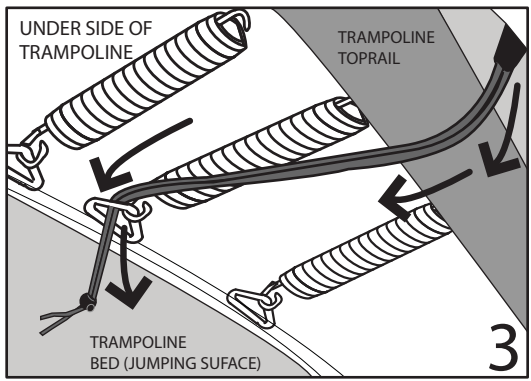
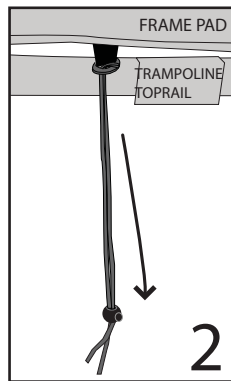
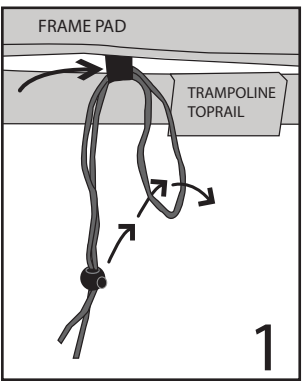

Repeat this process for ALL remaining black webbing tabs where cords will be placed.

Your Adjustable Pad is now fully assembled. Check once again to make sure all parts are secured on the frame pad before beginning use of the trampoline.

FRAME PAD ASSEMBLY

FOR USE ON **12FT ROUND** TRAMPOLINE FRAMES

(If you own a 14ft Round Trampoline please refer to the other section of this manual)

LAY THE FRAME PAD OVER THE FRAME OF THE TRAMPOLINE

Lay the Frame Pad on the frame. Adjust the position of the Frame Pad so the notches are aligned with the trampoline legs as shown (See below left). Please note that in assembling the 12ft PAD size there will be two sections of the pad that over lap. You will first need to fold back the over lap section to attach the frame pad buckles. (see below right).

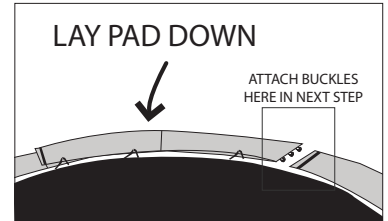
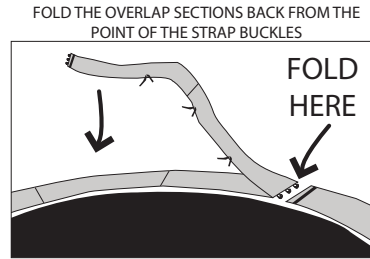
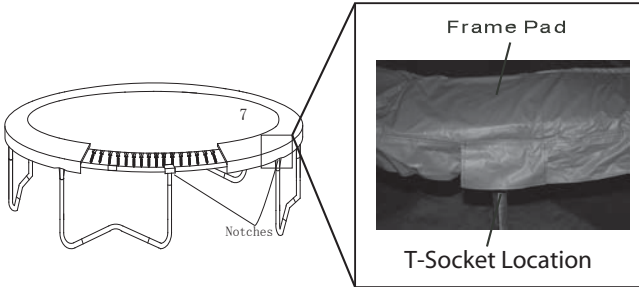

ASSEMBLE THE FRAME PAD IN THE CIRCULAR FORM

Once the frame pad is laid in the correct position on the frame, find the point at which the two ends of the pad connect together by the velcro. (see diagram 1). The pad will buckle together with the straps from the opposite sides in 3 locations as shown. (see diagram 2).

Diagram 1



Diagram 2

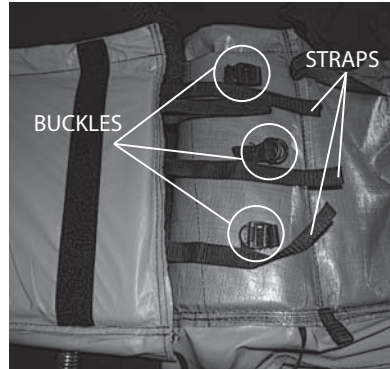

Next insert each strap into a buckle by following the steps below:

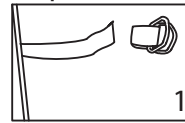

Straighten the strap so there are no kinks or twist in it.

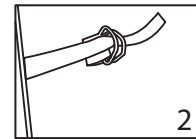

Insert the strap into both d-rings.

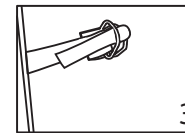

Wrap the strap back over the bottom ring and through the top ring. Be sure to keep the strap straight (see diagram 3)

Diagram 3



Diagram 4



Tighten all straps fully to secure them in place in the buckles (see diagram 4).

Finally, tuck all the straps and buckles under the pad and straighten out the 4 black ties so they are lined up as shown (see diagram 5).

Diagram 5



Finally, secure the end of the two pad sides together by tying a know in the each of the two straps of black webbing (see below LEFT). These straps are located near the bed/jumping surface of the pad. REMEBER: Tuck the straps under the pad away from the trampoline bed/jumping surface (4). Also tie a know in the straps located near the frame of the trampoline (see below RIGHT).

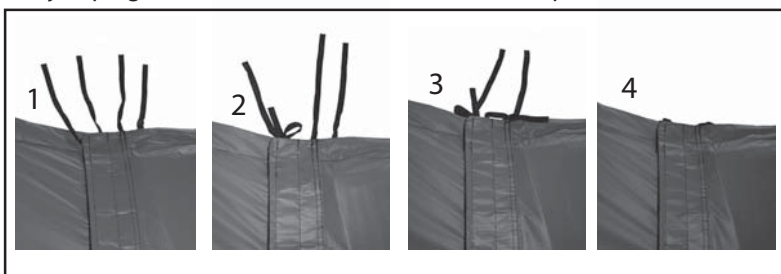

TIE TWO KNOTS NEAR BED/JUMPING SURFACE



TIE ONE KNOT NEAR FRAME TOPRAILS

FRAME PAD ASSEMBLY CONTINUED
FOR USE ON 12FT ROUND TRAMPOLINE FRAMES
 (If you own a 14ft Round Trampoline please refer to the other section of this manual)

OVER LAP THE FRAME SECTIONS AND CONNECT TO THE VELCRO FOR 12FT SIZE

Once the frame pad buckles are secure and the extra frame pad ties have been knoted: take the free end of the pad and fold it back over the top of the other sections of the frame pad to align with the velcro attachment.

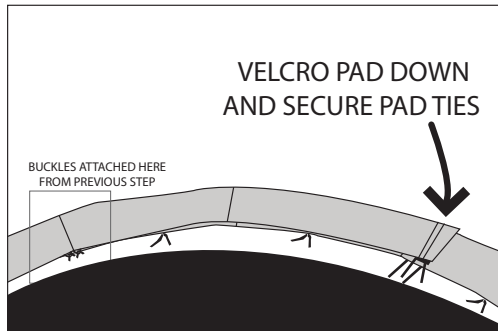
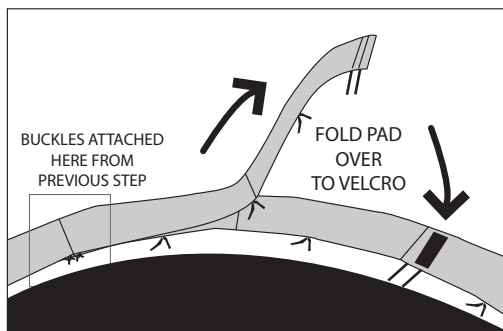

REMEMBER:
 Secure this end of the pad with the pad ties in the same way as the previous step

SECURE THE FRAME PAD TO THE FRAME OF THE TRAMPOLINE

Make sure the frame pad is still positioned in the correct location on the frame of the trampoline. There will be two types of straps to secure the pad. Find a starting point and first circle the trampoline in a clockwise pattern attaching all the ELASTIC TIE DOWN STRAPS.

These attachments are located on the inner ring of the frame pad and should be tied into the v-ring closest to them. It will make this step easier if you tie the straps from the UNDER side of the trampoline. (see right)

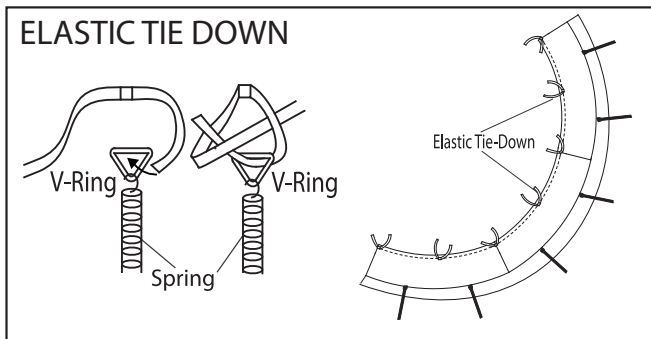

CORD LOCKS

Retrun to the starting location and again circle the trampoline in a clockwise pattern this time attaching all the CORD LOCK STRAPS. These attachments are located on the outer ring of the frame pad and should be wrapped around the top rail and looped through the v-ring closest to them. Follow the steps below for ALL the cord lock locations.

- Begin by threading the end of the cord lock with OUT the buckle throught the black webbing tab on the frame pad (1). Then loop the buckle through the free end of the cord (1).
- Next pull the buckle down as far as it will reach and tighten the loop into a knot at the webbing tab (2).
- Once the loop is tight, then wrap the cord around the OUTSIDE of the trampoline top rail, next to a spring, and into a v-ring nearest the cord. Be sure to enter the buckle through the TOP of the v-ring (3).
- Once the buckle has been pulled through the v-ring loop it around the ring back through the two sides of the cord (4).
- Finally pull up on the buckle to tighten the loop at the v-ring. Finish by pushing on the release of the buckle and pushing it all the way down until it touches the edge of the cord at the loop knot (5).

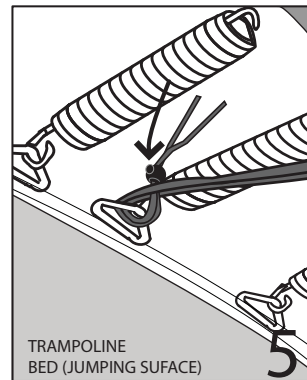
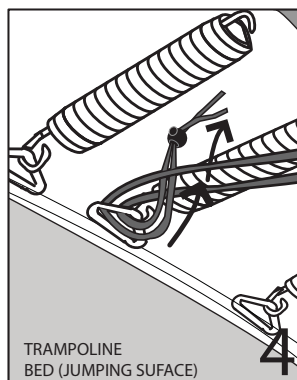
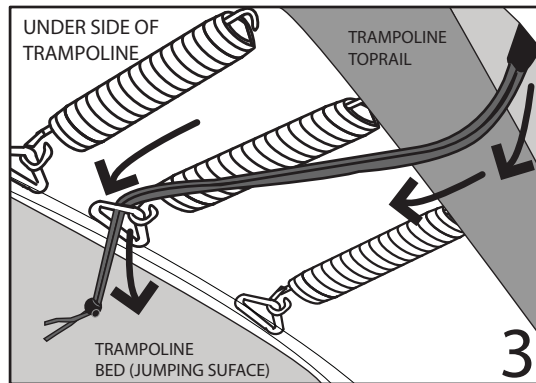
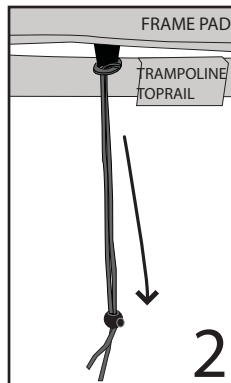
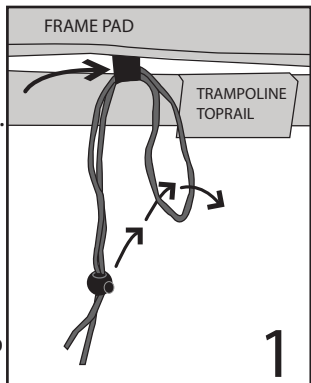

Repeat this process for ALL remaining black webbing tabs where cords will be placed.

Your Adjustable Pad is now fully assembled. Check once again to make sure all parts are secured on the frame pad before beginning use of the trampoline.