

JUMPKING®

9' X 13' OVAL COMBO

2.74M X 3.96M OVAL COMBO

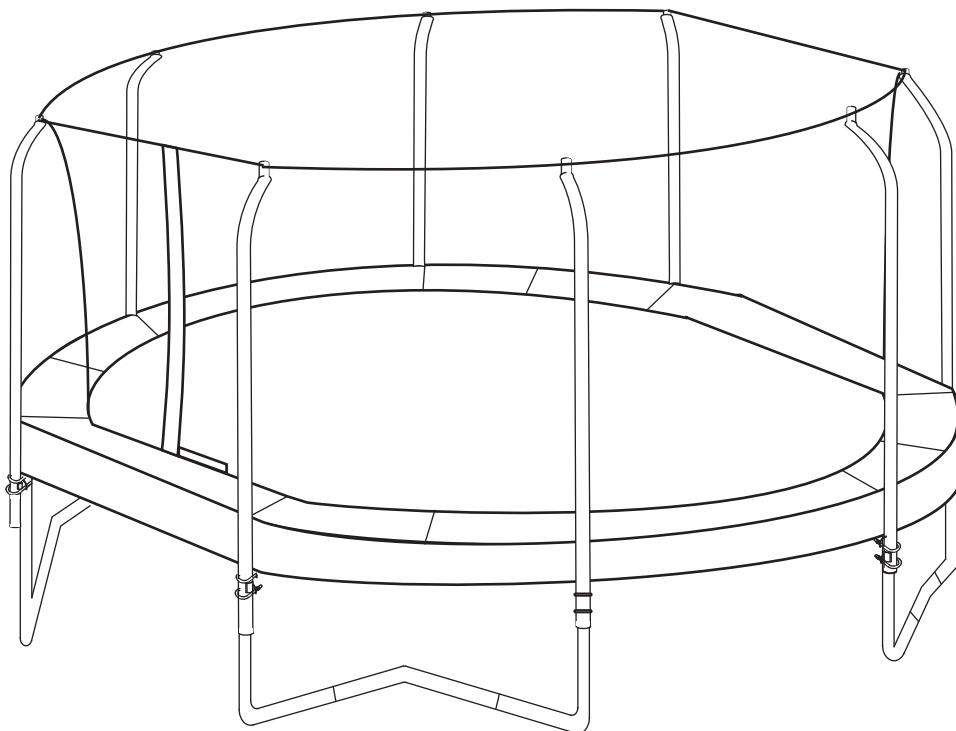

⚠ WARNING

Read the assembly, installation, care, maintenance, and use instructions in this manual prior to assembling and using this trampoline/enclosure. Save this manual for future reference.

USER'S MANUAL 3

Assembly, Installation, Care, Maintenance, and Use Instructions.

WARNING: The trampoline/enclosure is designed for users weighing 90 kg(200 lbs.) or less.

Ladder is not supplied with trampoline.

Do not use the trampoline without enclosure

QUESTIONS?

If you have questions after reading this manual, please call our toll-free Customer Hot Line. The trained technicians on our Customer Hot Line will provide immediate assistance.

Customer hot line : 03 9706 4475
Monday–Friday, 8 a.m.–5 p.m.

REPLACEMENT PARTS

JUMPKING®

9' X 13' OVAL COMBO

2.74M X 3.96M OVAL COMBO

CONTENTS

IMPORTANT PRECAUTIONS	4
WARNING LABEL PLACEMENT	6
BEFORE YOU BEGIN	7
TRAMPOLINE/ENCLOSURE SAFETY INFORMATION	7
USE AND INSTRUCTIONAL MATERIAL	11
ASSEMBLY	15
CARE AND MAINTENANCE	21
EXPLODED DRAWING AND PART LIST	22
ORDERING REPLACEMENT PARTS	22

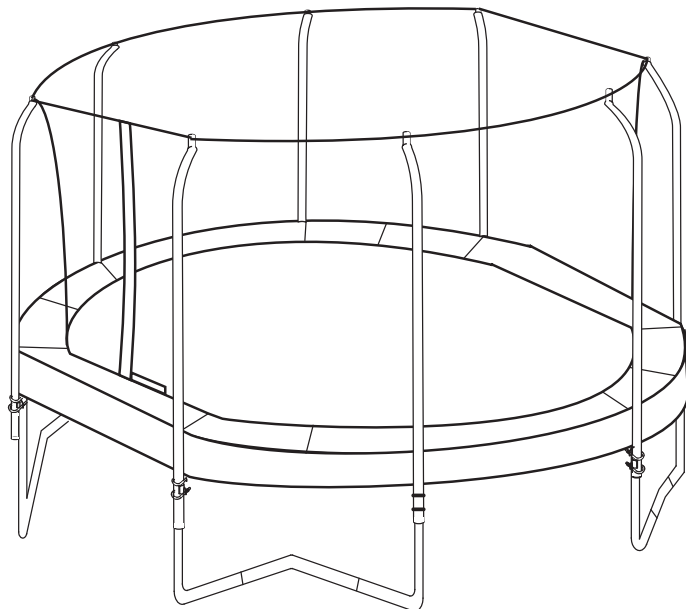



IMPORTANT PRECAUTIONS

⚠ WARNING: To reduce the risk of serious injury, read and follow all warnings, precautions, and instructions in this manual before assembling and using the trampoline and trampoline enclosure.



1. The owner and supervisors of the trampoline are responsible to make sure all the users are aware of practices specified in this manual.
2. Trained Spotter supervision is recommended.
3. Keep the trampoline on a level surface.
4. Must place the trampoline on lawn, bark wood chip, sand or cushioning materials.
3. Adequate overhead clearance is essential. A minimum of 8 m from ground level is recommended. Provide clearance for wires, tree limbs, and other possible hazards.
4. Maintain a free space of minimum 2500mm on all sides of the trampoline. This area should not include concrete, bitumen, brick, or other hard surfaces as these can cause serious injuries. Note: For Trampoline with enclosures, the free space may be reduced to 1500mm.
5. Lateral clearance is essential. Place the trampoline away from walls, structures, fences, and other play areas. Maintain a clear space on sides of the trampoline.
6. Use the trampoline in a well lighted area. Artificial illumination may be required for indoor or shady areas.
7. Secure the trampoline against unauthorized and unsupervised use. If an access ladder is used, it should be removed when the trampoline is not in use.
8. Inspect the trampoline and trampoline enclosure before each use. Make sure the frame padding is correctly and securely positioned. Replace any worn, defective, or missing parts.
9. Remove any obstructions from beneath the trampoline.
10. The trampoline is designed for users weighing 90kg (200 lbs.) or less. That trampolines greater than 500mm in height are not recommended for children under six years of age.
11. Allow only one person on the trampoline and trampoline enclosure at any time. Use by more than one person at the same time can result in serious injury.
12. Misuse and abuse of the trampoline is dangerous and can cause serious injuries.
13. Focus your eyes on the edge of the trampoline. This will help control your bounce.
14. Avoid bouncing for too long. Do not bounce when tired.
15. Stop your bounce by flexing your knees as your feet come in contact with the trampoline bed. Learn this skill before you attempt any others.
16. Climb on and off the trampoline, do not jump. It is a dangerous practice to jump from the trampoline to the floor or ground when dismounting, or onto the trampoline when mounting. Always use two hands on the frame getting on and off the trampoline. Never use springs or suspension elements as 'hand grips'.
17. Learn fundamental bounces and body positions thoroughly before trying more advanced skills. A variety of trampoline activities can be carried out by performing the basic fundamentals in various series and combinations, or performing one fundamental after the other, with or without bounces between them.
18. Avoid bouncing too high. Stay low until you can control your bounce and repeatedly land in the centre of the trampoline.
19. Do not use the trampoline as a springboard to other objects. Use the trampoline only for trampoline style bouncing.
20. Keep objects away that could interfere with the person jumping.
21. For further information or additional instructional materials, contact your nearest trampoline club.
22. It is advisable not to bounce immediately after a meal.
23. Do not attempt knee drops as these can cause injury if you attempt this skill without some experience or personal instruction.
24. Your clothing should allow plenty of body freedom, but no flapping shirts or skirts to distract your concentration.
25. No buckles or jewellery should be worn, as these could damage the trampoline mat and cause injury to you.

26. Do not wear shoes while bouncing on the trampoline.
27. Use the trampoline and trampoline enclosure only with mature, knowledgeable supervision at all times.
28. Injury may result from encountering the frame or falling through the springs while getting onto or off the trampoline or while jumping. Stay in the center of the bed when jumping. Do not use the trampoline without the frame pad securely in place to cover the frame. The frame pad is not designed or intended to support the weight of the user. Do not step or jump directly onto the frame pad.
29. The trampoline is a rebounding device that propels the user to unaccustomed heights and into a variety of body movements. Rebounding off the trampoline, striking the frame or springs, or improperly landing on the bed may cause injury.
30. Do not attempt or allow somersaults. This can result in a broken head, neck, back, or leg. Landing on the head or neck can cause serious injury, paralysis, or death, even landing on the middle of the bed.
31. Do not use a trampoline while under the influence of alcohol or drugs. These substances impair reaction time, judgement, and physical coordination.
32. Do not jump on the trampoline while holding an object, particularly one that is sharp or breakable.
33. Bounce only when the surface of the bed is dry. Wind or air movement should be calm to gentle. The trampoline must not be used in gusty or severe winds.
34. The trampoline enclosure is to be used only as an enclosure for a certain trampoline.
35. Do not attach anything to the netting that is not a manufacturer approved accessory or part of the enclosure.
36. Wear clothing free of drawstrings, hooks, loops, or anything that could get caught in the netting.
37. Enter and exit the trampoline enclosure only at the door designed for that purpose.
38. Do not attempt to crawl under the netting.
39. Do not attempt to jump over the netting.
40. Do not intentionally rebound off the netting.
41. Keep all frame and heat sources away from the product.
42. The trampoline frame and the enclosure are made of metal. They are not grounded, and they will conduct electricity. Therefore, an electrocution hazard exists.
43. Keep objects away which could interfere with the user. Maintain a clear area around, above, and under the trampoline.
44. Do not use trampoline without enclosure.
45. Do not use the trampoline when wet.
46. Do not jump onto or off the trampoline.
47. Do not allow any activity underneath the trampoline.
48. Do not use trampoline without mature, and knowledgeable supervision.
49. The following conditions could represent potential hazards:
 - (i) Missing, improperly positioned, or insecurely attached frame padding.
 - (ii) Punctures, frays, tears or holes worn in the bed or frame padding.
 - (iii) Deterioration in the stitching or fabric of the bed or frame padding.
 - (iv) Broken or stretched springs.
 - (v) A bent or broken frame.
 - (vi) A sagging bed.
 - (vii) Sharp protrusions on the frame, padding or suspension system.
 - (viii) Damaged or degraded padding.

WARNING PLACARD PLACEMENT

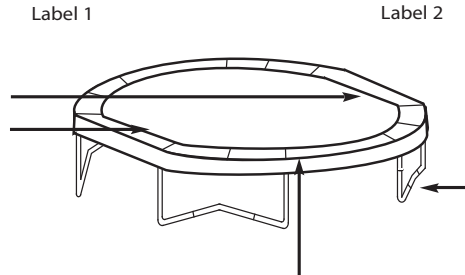
! WARNING	
	<ul style="list-style-type: none"> Do not use trampoline and trampoline enclosure without mature, and knowledgeable supervision . Do not attempt or allow somersaults . Do not allow more than one person on the trampoline and trampoline enclosure at any time . Do not use the trampoline when wet. Do not jump onto or off the trampoline. Do not use a trampoline while under the influence of alcohol or drugs. Do not allow any activity underneath the trampoline. Do not use trampoline without enclosure.
	<ul style="list-style-type: none"> Inspect the trampoline before each use. Make sure the frame padding is correctly and securely positioned. Replace any worn, defective, or missing parts. Keep objects away which could interfere with the user. Maintain a clear area around, above, and under the trampoline. Learn fundamental bounces and body positions thoroughly before trying more advanced skills.
DO NOT USE WITHOUT FRAME PADS! - MAXIMUM USER MASS 90 KG.	
<p>YJ Industrial Co., Made of 100% Polypropylene Made In China</p>	
<p>Manufacturer: YJ INDUSTRIAL CO., Tel: 00603-62750318 Customer services: GLOBAL LEISURE CONCEPTS PTY LTD Tel: 03 9706 4475 Model: JK91323</p>	



! WARNING	
	<ul style="list-style-type: none"> Do not use trampoline and trampoline enclosure without mature, and knowledgeable supervision . Do not attempt or allow somersaults . Do not allow more than one person on the trampoline and trampoline enclosure at any time . Do not use the trampoline when wet. Do not jump onto or off the trampoline. Do not use a trampoline while under the influence of alcohol or drugs. Do not allow any activity underneath the trampoline. Do not use trampoline without enclosure.
	<ul style="list-style-type: none"> Inspect the trampoline before each use. Make sure the frame padding is correctly and securely positioned. Replace any worn, defective, or missing parts. Keep objects away which could interfere with the user. Maintain a clear area around, above, and under the trampoline. Learn fundamental bounces and body positions thoroughly before trying more advanced skills.
DO NOT USE WITHOUT FRAME PADS! - MAXIMUM USER MASS 90 KG.	
<p>Manufacturer: YJ INDUSTRIAL CO., Tel: 00603-62750318 Customer services: GLOBAL LEISURE CONCEPTS PTY LTD Tel: 03 9706 4475 Model: JK91323</p>	

! WARNING	
	<p>Do not use trampoline and trampoline enclosure without mature, and knowledgeable supervision .</p> <p>Do not attempt or allow somersaults .</p> <p>Do not allow more than one person on the trampoline and trampoline enclosure at any time .</p> <p>Do not use the trampoline when wet.</p> <p>Do not use a trampoline while under the influence of alcohol or drugs.</p> <p>Do not allow any activity underneath the trampoline.</p> <p>Do not use without frame pads.</p> <p>Do not use trampoline without enclosure.</p>
	<p>Inspect the trampoline before each use. Make sure the frame padding is correctly and securely positioned. Replace any worn, defective, or missing parts.</p> <p>Keep objects away which could interfere with the user. Maintain a clear area around, above, and under the trampoline.</p> <p>Learn fundamental bounces and body positions thoroughly before trying more advanced skills.</p>
DO NOT USE WITHOUT FRAME PADS! - MAXIMUM USER MASS 90 KG.	
<p>Manufacturer: YJ INDUSTRIAL CO., Tel: 00603-62750318 Customer services: GLOBAL LEISURE CONCEPTS PTY LTD Tel: 03 9706 4475 Model: JK91323</p>	



This labels shown on this page have been attached to the trampoline in the indicated locations. The placard will be attached by the owner(see step 6 on page 18). If one of the labels or the placard is missing or illegible, call our Customer Hot Line(see page 3) and order a free replacement label or placard. Attached the label or placard in the location shown.

Placard
(to be attached
by the owner)

Note: The labels and the placard are not shown actual size.

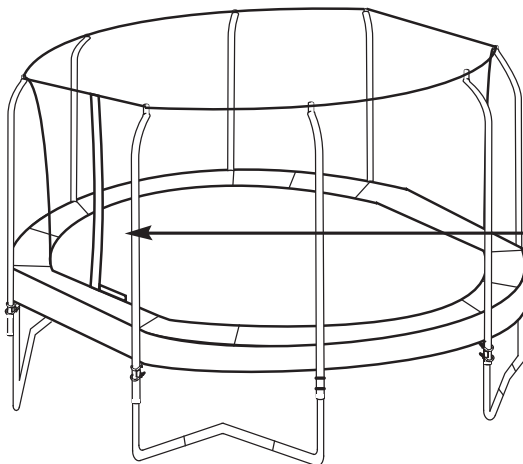
The placard shown at the right must be attached to the trampoline enclosure by the owner (see assembly step 15 on page 21). If the placard is missing or illegible, call our Customer Hot Line toll-free at 03 9706 4475, Monday through Friday, 8 a.m. until 5 p.m. Central Time, to order a free replacement placard. Note: The placard is not shown actual size.



! WARNING	
	<ul style="list-style-type: none"> Do not use trampoline and trampoline enclosure without mature, and knowledgeable supervision . Do not attempt or allow somersaults . Do not allow more than one person on the trampoline and trampoline enclosure at any time . Do not use the trampoline when wet. Do not jump onto or off the trampoline. Do not use a trampoline while under the influence of alcohol or drugs. Do not allow any activity underneath the trampoline. Do not use trampoline without enclosure.
	<ul style="list-style-type: none"> Inspect the trampoline before each use. Make sure the frame padding is correctly and securely positioned. Replace any worn, defective, or missing parts. Keep objects away which could interfere with the user. Maintain a clear area around, above, and under the trampoline. Learn fundamental bounces and body positions thoroughly before trying more advanced skills.
DO NOT USE WITHOUT FRAME PADS! - MAXIMUM USER MASS 90 KG.	
<p>Manufacturer: YJ INDUSTRIAL CO., Tel: 00603-62750318 Customer services: GLOBAL LEISURE CONCEPTS PTY LTD Tel: 03 9706 4475 Model: JK91323</p>	

BEFORE YOU BEGIN

Thank you for selecting a Combo trampoline/ enclosure. "Combo" are designed and crafted to provide many years of fun and fitness. This trampoline/enclosure come equipped with warnings and instructions for the assembly, care, maintenance, and use of the trampoline/enclosure. This information must be read by all trampoline supervisors and users before any person is allowed to jump and use enclosure on the trampoline.

If you have questions after reading this manual, please call our Customer Hot Line at 03 9706 4475, Monday - Friday, 8 a.m. until 5 p.m. Central Time (excluding holidays). To help us assist you, please mention the name of the product when calling.

TRAMPOLINE SAFETY INFORMATION

In trampoline use, as in all active recreational sports, participants can be injured. However, there are steps that can be taken to reduce the risk of injury. In this section, primary accident patterns are identified and the responsibilities of supervisors and jumpers in accident prevention are described.

ACCIDENT CLASSIFICATION

Somersaults (flips): Landing on your head or neck, even in the middle of the trampoline bed, increases the risk of a broken back or neck, which can result in paralysis or death. Such events can occur when a jumper makes an error trying to perform a forward or backward somersault (flip). Do not perform somersaults (flips) on this backyard trampoline.

Multiple Jumpers: More than one jumper on the trampoline increases the chance of a jumper becoming injured by losing control of his or her jump. Jumpers may collide with one another, fall off the trampoline, fall on or through the springs, or land incorrectly on the bed. The lightest weight jumper is the jumper most likely to be injured.

Mounting and Dismounting: The trampoline bed is several feet from ground level. Jumping off the trampoline to the ground or any other surface may result in injury. Jumping onto the trampoline from a roof, deck, or other object also represents a risk of injury. Smaller children may need assistance getting onto or down from the trampoline. Climb carefully onto and off the trampoline. Do not step onto the springs or the frame pad. Do not grasp the frame pad to pull yourself onto the trampoline.

Striking the Frame or the Springs: Injury may result from encountering the frame or falling through the springs while jumping or getting onto or off the trampoline. Stay in the center of the bed when jumping. Make sure to keep the frame pad in place to cover the frame. The frame pad is not designed nor intended to support the weight of the trampoline user. Do not step or jump directly onto the frame pad.

Loss of Control: Jumpers who lose control of their jump may land on the bed incorrectly, land on the frame or springs, or fall off the trampoline. A controlled jump is one where the landing is in the same spot as the takeoff. Before learning a more difficult maneuver, the preceding one should be performed consistently under control. Attempting a maneuver beyond present skill levels increases the chance of loss of control. To regain control and stop your jump, bend your knees sharply when you land.

Alcohol or Drug Use: The chance of injury increases when a jumper has consumed alcohol or taken drugs. These substances impair a person's reaction time, judgment, and physical coordination.

Encountering Objects: Use of a trampoline while other people, pets, or objects are underneath it will increase the chance of injury. Jumping while holding or having an object on the trampoline, particularly one that is sharp or breakable, will increase the chance of injury. Placing a trampoline too close to overhead electrical wires, tree limbs, or other obstructions can increase the chance of injury.

Poor Maintenance of the Trampoline: Jumpers may be injured if a trampoline is used when it is in poor condition. A torn bed, bent frame, broken spring, or missing frame pad, for example, should be replaced before anyone is allowed to jump. Inspect the trampoline before each use.

Weather Conditions : A wet trampoline bed is too slippery for safe jumping. Gusty or high winds can cause jumpers to lose control. To reduce the chance of injury, use the trampoline only under appropriate weather conditions.

Access: To prevent access to the trampoline by unsupervised smaller children, the access ladder should always be removed and stored in a secure location when the trampoline is not in use.

METHODS OF ACCIDENT PREVENTION

The Supervisor's Role in Preventing Accidents

It is the responsibility of the supervisors of trampoline users to provide knowledgeable and mature supervision. They need to know and enforce all the rules and warnings set forth in this manual to minimize the likelihood of accidents and injuries and to inform users of these rules. During periods of time when supervision is unavailable or inadequate, this may require that the trampoline be disassembled, placed in a secure area, or otherwise secured against unauthorized use. Another option that may be considered is covering the trampoline with a heavy tarp that can be secured with locks and chains. It is the responsibility of the supervisor to make sure that the placard with TRAMPOLINE SAFETY INSTRUCTIONS (see step 7 on page 18) is kept posted on the trampoline and that jumpers are informed about these instructions.

The Jumper's Role in Preventing Accidents

Education on the part of the user is a must for safety. Users must first learn a low, controlled bounce and then learn the basic landing positions and combinations before proceeding to intermediate skills. Jumpers must understand why they have to master "control" before they can start thinking about other moves. Understanding the proper progression of skills in jumping on a trampoline must be the first lesson. Review this manual to learn about the basic techniques for using the trampoline. Follow the rules on the placard with TRAMPOLINE SAFETY INSTRUCTIONS (see step 7 on page 18). For further information or additional instructional materials, contact a certified trampoline instructor.

TRAMPOLINE SAFETY INSTRUCTIONS

For the Supervisor

Read the instructions before using the trampoline. Enforce all of the safety rules and be familiar with the information in this manual to help new users learn basic jumps and all users follow trampoline safety. All trampoline users must have mature, knowledgeable supervision, regardless of the skill or age of the jumper.

This trampoline is not recommended for use by children under 6 years of age.

Inspect the trampoline before using it. Do not use the trampoline without the frame pad securely in place to cover the frame. Do not use the trampoline when it is wet or in a windy condition. A worn or damaged bed, spring, or frame piece should be replaced immediately.

Keep objects away that could interfere with the jumper.

Secure the trampoline against unauthorized and unsupervised use.

For the Jumper

Do not use the trampoline when under the influence of drugs or alcohol.

Avoid bouncing when tired.

JUMPING

Learn fundamental jumps and body positions thoroughly before trying more advanced skills. Be alert to your own limitations in the execution of trampoline skills. Review this manual to learn how to do basic jumps.

Stop your bounce by flexing your knees as your feet come in contact with the trampoline bed. Learn this skill before attempting others.

Avoid jumping too high or for too long. Always control your jump. A controlled jump is one where the takeoff and landing spots are the same.

Bounce in the center of the trampoline. Focus your eyes on the frame pad. Failure to do so may result in a loss of balance and control.

Take turns jumping, one at a time, and always have someone watch you.

GETTING ON AND OFF

Climb onto and off the trampoline; do not jump onto it or off it. Do not use the trampoline as a springboard to other objects. For additional information regarding skill training, contact a trainer certification organization.

TRAMPOLINE ENCLOSURE SAFETY INFORMATION

NEED FOR TRAMPOLINE ENCLOSURE SAFETY

A trampoline enclosure is a recreational product.

The information on this page and on page 10 identifies important safety precautions. The precautions are not all-inclusive, because an enclosure can be used in ways that this manual cannot cover completely.

To prevent pinches and cuts during enclosure use, a frame pad must be installed on the trampoline. (See the trampoline manufacturer's instructions.) The frame pad must be installed before the enclosure is erected. The frame pad reduces the chance of injury from accidental contact with the springs and frame.

USING THE ENCLOSURE SAFELY

Adult Supervision of Children

Children using a trampoline with a trampoline enclosure must be supervised by adults. Young children must be supervised constantly. Adults must pay particular attention to:

- things that children bring into the enclosure.
- children's activities inside the enclosure.
- conditions inside the enclosure while children are using it.
- the way children get into and out of the enclosure.

Additional details of safe enclosure use are described below.

Electrocution Hazard Associated with the Metal Frame of the Trampoline and Enclosure

The trampoline and enclosure frames are made of metal. They are not grounded, and they will conduct

electricity. Lights, electric heaters, extension cords, and household electrical appliances are not permitted in or on the trampoline or enclosure.

Hazards Associated with Entering and Exiting the Trampoline Enclosure

A trampoline enclosure installed on a trampoline is raised off the ground. The height of the enclosure increases the risk of a fall when a jumper is entering or exiting the enclosure. Young children in particular may have difficulty getting into and out of the enclosure. To reduce the risk of falling, help young children to get into and out of the enclosure.

Enter and exit the trampoline enclosure only through the door of the enclosure (the opening in the netting walls). The trampoline bed and the netting walls of the enclosure are separate pieces; jumpers, particularly young children, must not exit the enclosure by going out between the bed and the netting walls. Trying to exit in this way poses a risk of strangulation from being caught between the trampoline frame and the netting walls.

Darkness increases the chances of a fall when a jumper is entering or exiting the enclosure. Do not use the trampoline unless adequate lighting is provided.

Hazards Associated with Animals and Sharp and Breakable Objects

To avoid damage to the trampoline enclosure and the trampoline, do not allow pets or other animals inside of the enclosure. The claws and teeth of animals can damage the netting. Do not jump on the trampoline while holding or wearing a sharp or breakable object.

Hazards Associated with High Winds

A trampoline with an enclosure can be moved or blown over by high winds, potentially injuring anyone in its path or anyone inside of the enclosure. If you anticipate high winds, take down the enclosure netting, and stake the trampoline frame to the ground (see page 21), or move the trampoline and enclosure to a sheltered location.

Storing the Trampoline Enclosure Safely

Specific steps for storing the trampoline enclosure are presented later in this manual. There are specific safety precautions to be aware of when storing the enclosure.

Remove the attached tube sections as a unit, and separate them on the ground. Avoid pinching your fingers by keeping your fingers away from pinch points near the bracket assembly while you are removing the tubes from the frame.

Placing the Trampoline in a Safe Place

There must be at least 8 m of clear, open space above the trampoline bed. Do not place or store anything underneath the trampoline.

To avoid injury, the trampoline must be kept away from objects and possible hazards including electric power wiring, tree limbs, and fences. Do not place the trampoline near any other recreational devices or structures such as a swimming pool or swing set.

The trampoline must be placed on a level surface before use, and the area around the trampoline must always be well lighted.

For the Supervisor

Be familiar with the information in this manual and enforce all of the safety rules. Help new users and all users to use the trampoline and enclosure safely.

All trampoline users must have someone watch them, regardless of the skill or age of the user.

Secure the trampoline against unauthorized and unsupervised use. Keep the trampoline free of objects that could interfere with the jumper.

This trampoline enclosure is not recommended for use by children under 6 years of age or by anyone weighing more than 200 lbs (90 kg).

Use the trampoline only when the bed is clean and dry. Inspect the trampoline and enclosure prior to each use and replace any worn or damaged parts. Use only when the enclosure netting has no holes, the clamps are tightly secured to the tubes and the frame, and the netting is properly suspended.

For the Jumper

Do not attempt to jump over the netting. Do not intentionally rebound off the netting. Do not hang from, kick, cut, or climb on the netting.

Wear clothing that is free of drawstrings, hooks, loops or anything that could get caught in the netting.

Do not attach anything to the netting that is not a Bazoongi approved accessory or part of the trampoline enclosure.

How to Enter and Exit the Trampoline Enclosure

Enter and exit the trampoline enclosure only through the door in the netting. To enter the enclosure, first unfasten the plastic clips on the door and unzip the zippers. Place one knee on the frame pad and climb head first through the door. Refasten the plastic clips and close the zippers.

To exit the enclosure, first unzip the zippers on the door and unfasten the plastic clips. Sit on the bed of the trampoline and climb feet first through the door. When you are through the door and sitting on the frame pad, step or jump safely to the ground. Close the zippers and refasten the plastic clips.

USE AND INSTRUCTIONAL MATERIAL

OVERVIEW OF TRAMPOLINE USE

The first periods of trampoline use should focus on learning fundamental body positions and practicing the eight basic bounces that are described on pages 13 and 14 in this manual.

During this learning period, jumpers should practise these basic techniques and perfect them. Braking, or checking the bounce, should be taught first and stressed as a safety measure. Jumpers should brake their jump whenever they start to lose balance or control. This is done by simply flexing the knees sharply upon landing and absorbing the upward thrust of the bed. This enables the jumper to stop suddenly and avoid losing control.

In trampoline use, the takeoff point and landing point of a good, controlled jump are in the same spot. An exercise is considered learned only when a jumper is able to perform it consistently. Jumpers should never proceed to any advanced step until they can perform all previous techniques consistently.

Allow each jumper a brief turn on the trampoline. Extended bouncing exposes an overtired user to an increased risk of injury. Longer turns tend to lessen the interest of others waiting to jump. Clothing should consist of a T-shirt and shorts. Jumpers should wear regulation gymnastic shoes or heavy socks, or they may jump barefoot. Street shoes or tennis shoes

should not be worn on the trampoline. Beginning jumpers may wish to wear loose-fitting protective clothes, such as a long-sleeve shirt and pants, until correct landings are mastered. This will reduce the chance of mat (bed) burns from improper landings on elbows and knees. No hard-sole shoes should be worn, as they cause excessive wear on the trampoline bed.

Mounting and dismounting properly should be a strict rule from the beginning. Users should climb onto the trampoline by placing their hands on the frame and stepping or rolling up onto the frame, across the springs, and onto the bed. Do not step directly onto the frame pad or grasp the frame pad when mounting or dismounting the trampoline. Users should always place their hands on the frame while mounting or dismounting. To dismount, jumpers should walk to the side of the bed, bend over and place one hand on the frame, and then step from the bed to the ground. If you have installed the optional ladder, its rungs can be used to mount or dismount. Always face the ladder and place your hands on the frame. Make sure your foot has secure contact with the ladder rung when using it.

Reckless bouncing should not be permitted. All skills should be learned at moderate heights. Control, rather than height, should be emphasized. Jumpers should be forbidden to practice alone and unsupervised.

Instruction program and model lessons

These instructions contain information on basic skills (see paragraph 2), landing positions (see paragraph 3), and how to perform series of drops. The instructions are ordered according to difficulty.

Basic Skills

Bouncing

The most important thing about bouncing is that it should be done with control in the centre of bed. The basic bounce should always begin low. High, reckless bouncing should never be allowed.

1. The stop bounce

This technique allows the jumper to gain control by stopping quickly. It is achieved by keeping the feet in contact with the bed, and absorbing the rebound of the trampoline with the knees and waist. This skill should be the first skill learnt and should be employed whenever you feel out of balance, or land away from the center area.

To learn the stop bounce:

- Stand in centre of the bed with your feet about hip-width apart.
- Attempt about three easy bounces, keep them low and controlled.
- Focus your eyes towards the perimeter of the trampoline while bouncing in order to keep your balance.
- Stop the bounce by bending at your knees and hips on contact with the bed.

2. Arm Action

Arms are very important for proper control and lift. whenever you go up, your arms go up. They go up to a set position about shoulder height and shoulder width. They should remain in this balanced position until you start down. Then they circle down and slightly behind the hips, ready to lift again as you bounce up.

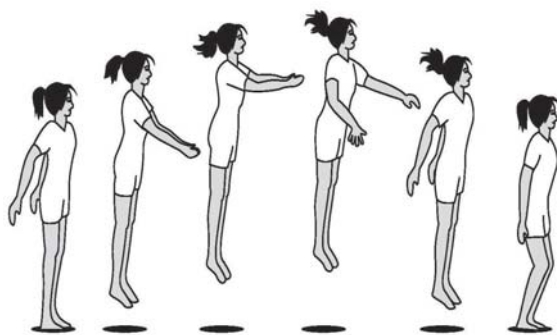

Figure 1, Arm Action

3. Bounce Variations

Figure 2, 3, 4 show three variation, the tuck, the pike, and the straddle pike respectively. These should be assumed at the top of the bounce, before resuming the normal landing position on your feet.



Figure 2, Tuck



Figure 3, Pike



Figure 4, straddle Pike

Practice these simple variations and concentrate on perfect form. Make sure that your toes are pointed and fingers are straight.

These are simple variations to the basic bounce and are very important for gaining experience in coordinated movement.

Basic Landing Positions

General

Positions for all drops: Seat (see paragraph 1. The Seat Drop), hands and knees (see paragraph 2. The hands and knees drop) and front (see paragraph 3. The front drop), should first be practiced on the ground, then in a stationary position, and only then on the trampoline bed.

Drop should be performed after 'priming' the trampoline bed. Priming is done by bending your knees and pushing down repeatedly on the trampoline bed, thereby setting the bed in motion. The feet stay in contact with the bed during the entire priming motion.

1. The Seat Drop

To learn the seat drop:

- From the standing position, prime the bed several times.
- Pick up your feet at the top of the last bounce, and sit down. You should land so that your body is in a sitting position with legs straight out in front and your toes pointed. Hands should be on the bed next to your hips. Fingers should be together and pointed toward the toes.
- Push on the bed with your hands to rebound up to your feet (see Figure 5).



Figure 5, Seat drop

3. The hands and knees drop

To do this drop properly, there should be just as much weight on your hands as on your knees. Your back should be about approximately parallel to the bed. Knees and hands should land simultaneously, with the middle of the body landing in the centre of the trampoline. Hands should be directly under the shoulders. Knees should be directly under the hips. Your toes should be pointed.

To learn the hands and knees drop:

- Get down on your hands and knees on the bed. Make sure you have weight on both your hands and your knees. Do not sit on your heels.
- Remain in this position and try to bounce. Do not rock back and forth between the hands and knees, but develop an even landing on all four points.
- From the standing position, prime the bed several times. Lift upward with your hips, reach forward with your hands, and land on all fours. Look slightly in front of your hands on landing. Push to rebound to your feet (see Figure 6).

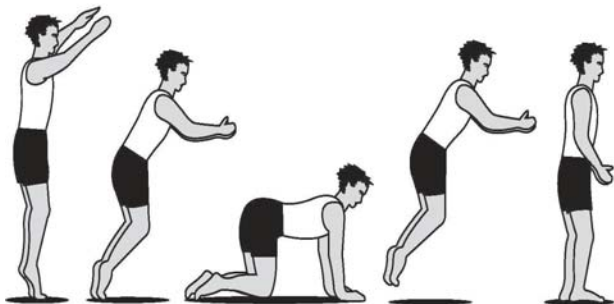

Figure 6: Hands and knees drop

4. The front drop

Contact with the trampoline bed should simultaneously take place with your hands, elbows, chest, stomach, hips, and knees. Knees should be bent. You must come down level. If the landing is made first on your chest and arms, they will rebound before your knees hit which will result in a straining action on your back. If this type of landing is made with a travelling, diving approach there is a chance that your elbows may become skinned. If the landing is made so that your knees and hips hit first, then they will rebound and your shoulders and face will land heavily.

Step 1:

- Start from the hands and knees drop position.
- As you rebound from the hands and knees, stretch so that you land on your stomach. From this position, rebound to your hands and knees.

Step 2:

- Start from a standing position with knees bent so that your upper body is low and close to the trampoline bed.
- Prime the bed several times.
- Lift hips gently upward and backward.
- Land in contact with the bed as described in Step 1.
- Push with your hands to return to the feet.

Step 3:

- Start from a straight standing position.
- Prime the bed several times.
- Perform skill as in Step 2 (see Figure 7).

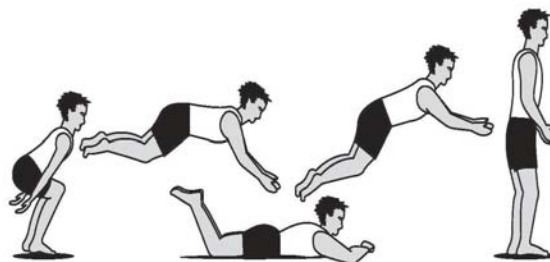

Figure 7: Front drop

SERIES OF DROPS

1. Sequencing

Once you have mastered the individual bounce variations and drops, practice them in sequence. For example: Seat drop—Hands and knees drop—Front drop, or Seat drop—Front drop—Hands and knees drop—Seat drop.

2. Beginning twisting

General

Figures 8, 9, and 10 will show you a few of the many possible twisting variations of the basic landing positions.

Seat drop—Half twist—Seat drop (AKA: Swivel hips)

Step 1:

- Perform a seat drop.
- Push down on the bed with your hands and come to a stand with the arms stretched overhead.

Step 2:

- Perform the movement in Step 1. As you rebound up to your feet, move one shoulder in the direction you want to twist.
- Finish standing with arms stretched overhead, facing the opposite direction (180 degree twist completed).

Step 3: Perform as in Step 2. Just before contacting feet with the trampoline bed, lift your legs to land in a sitting position (see Figure 8).

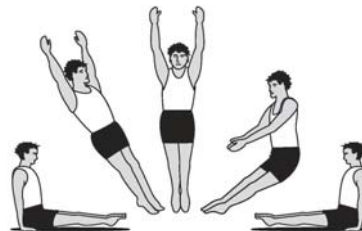

Figure 8: seat drop - half twist - seat drop

Front drop—Half twist—Front drop (AKA: Turntable)

Step 1:

- (a) Begin in a hands and knees position, with hands forming the apex of a triangle, like in a front drop.
- (b) Prime the bed in this position.
- (c) Push backward with your hands and extend your body to land in the front drop position.
- (d) Repeat several times in succession: Hands and knees drop—Front drop—Hands and knees drop—etc.

Step 2: Perform the movement as in Step 1. However, do it at twice the speed so as to bring your knees inward, under your hips and out again without touching your knees on the bed.

Step 3: Perform the movement as in Step 2. Push sideways on the trampoline bed so that your body rotates.

Step 4: From a standing position, prime the bed, then perform a front drop. Push sideways, as in Step 3, and complete a 180 degree turn, finishing in a front drop facing the opposite position (see Figure 9).

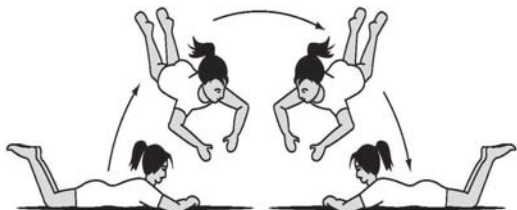

Figure 9: Front drop - half twist - front drop

Seat drop—Full twist—Seat drop (Full barrel roll)

Perform this as you would a half barrel roll but keep moving your shoulder in the direction of the twist so that you finish in the seat drop position. During the twist, hands should be placed by your sides, with your body held straight (see Figure 10).

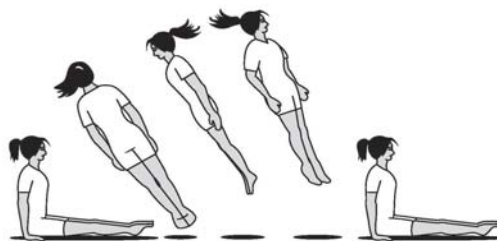

Figure 10: Seat drop - full twist - seat drop

ADDITIONAL TWISTING

You can combine a twist with each of the basic landing positions (see Paragraph 3). You can twist after the landing position.

Example: Seat drop— $\frac{1}{2}$ twist—feet

You can add more twists. Remember to practice and perfect the smaller twists before moving on to larger twists.

You can also perform a series of twists.

Example: Swivel hips—perform several in a row, all twisting in one direction, or alternating directions.

ASSEMBLY

IMPORTANT ASSEMBLY INFORMATION

- Assembly requires a 8/16" socket and ratchet(or a 8/16" open-end wrench) and a Phillips Head screw driver are needed to assemble trampoline/ enclosure. However, socket ,ratchet, open-end wrench and screw driver are not provided.
- Assembly requires two or three persons. Keep children away from the trampoline/enclosure until it is fully assembled.
- Use gloves to protect your hands from pinch points during assembly.
- The assembly steps refer to parts by their descriptions and key numbers (see the PART LIST on page 22). If a part is missing, see ORDERING REPLACEMENT PARTS on page 22.

TRAMPOLINE/ENCLOSURE PLACEMENT

1. Place the trampoline/enclosure on a level surface before use.
2. Adequate overhead clearance is essential. A minimum of 7.3 m (24 ft.) from ground level is

recommended. Provide clearance for wires, tree limbs, and other possible hazards. Lateral clearance is also essential. Place the trampoline/enclosure away from walls, structures, fences, and other play areas. Maintain a clear space on all sides of the trampoline/enclosure.

3. Use the trampoline/enclosure in a well-lighted area. Artificial illumination may be required for indoor or shady areas.
4. Secure the trampoline/enclosure against unauthorized and unsupervised use.
5. Remove any obstructions from beneath the trampoline/enclosure.
6. The owner and supervisors of the trampoline are responsible to make all users aware of practices specified in this manual.
7. The trampoline/enclosure is only to be used as an enclosure for a round trampoline.

- 1 a. Make sure you understand the information in the box at the top of this page before you begin assembling the trampoline.

Lay top tube (1, A with T-connector and 2, B with Socket) on the ground as shown.

Insert top tube(1, A) with smaller end into top tube(2, B with socket). Insert the another top tube(1, A with T-connector) to another side of top tube(2, B) with smaller end.

Insert two L-legs (6) into two T-connector(5). Insert a center leg(7) into L-leg(6), slide a second leg (6) onto the base. Tighten self-tapping screws (22) into the small holes in two L-legs (6).

- b. Lay top tube (1 A with T-connector, 2 B with Socket, 3 C with T-connector and 4d with Socket) on the ground as shown.

Insert top tube (1, A) with smaller end into top tube(2, B with socket).

Insert top tube(1, A) with smaller end into top tube(2, B with socket). Insert the straight top tube(3, C with T-connector) to another side of top tube(2, B) with smaller end.

Then insert a straight top tube (4, D with Socket) into straight top tube(4, D) with smaller end.

Insert two L-legs (6) into T-connector(5). Insert a center leg(7) into L-legs(6), slide two legs(6) onto the base. Tighten self-tapping screws (22) into the small holes in two L-legs(6).

You have now assembled two sections. Repeat these steps to assembled remaining sections.

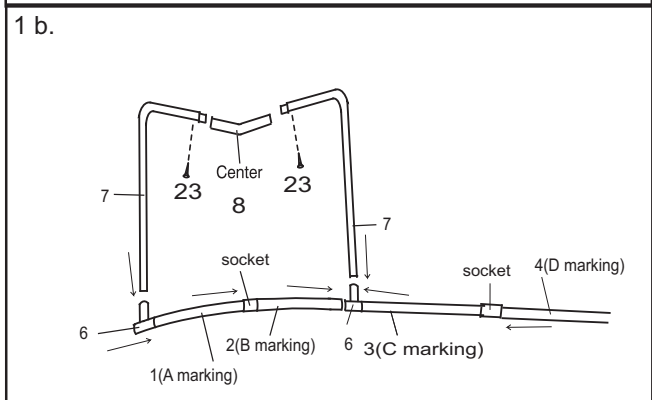
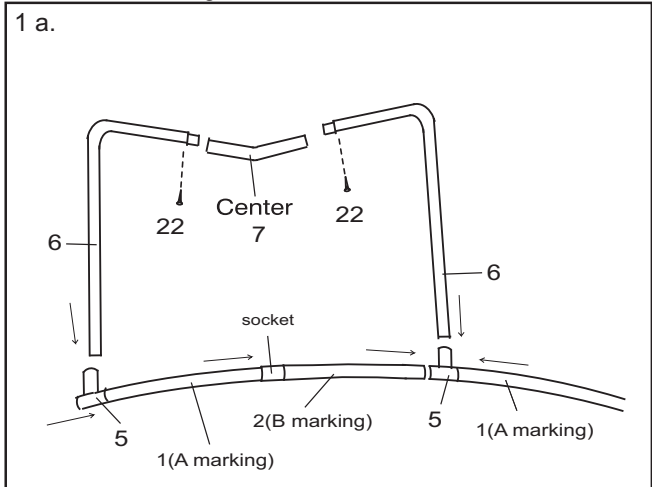

2. Note: This step requires two or three persons. During this step, you will connect the four leg sections.

Hold leg sections in the positions shown. Insert the top tube (1, A marking) with smaller end into the T-connector (5). Then insert straight top tube (4, D marking) with smaller end into T-connector(5).

Repeat this step until all four leg sections are connected.

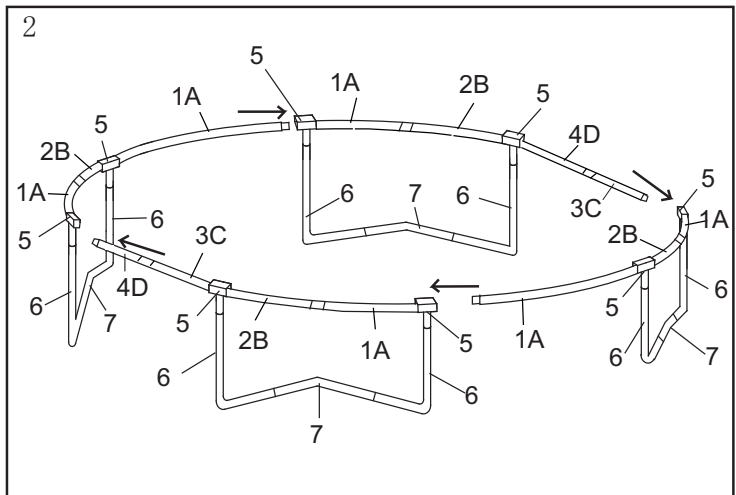

3. Lay the Bed(9) on the ground inside of the assembled frame. Make sure that the two warning decals (not shown) are on top of the Bed.

Note: There are V-rings around the edge of the Bed(9) and holes around the top of the frame. During this step, you will attach the Bed to the frame using the included Spring(8).

To attach each Spring, you will first hook one end of the Spring into a V-ring with black webbing with yellow line location (see the inset drawing). Next, you will hook a second Spring (not shown) to the free end of the first Spring, and use the spring pulling tool(23) to pull the first Spring until it reaches the frame. You will then push the end of the first Spring into a hole in the frame. Be careful where you place your hands, the Springs and frame joints can pinch.

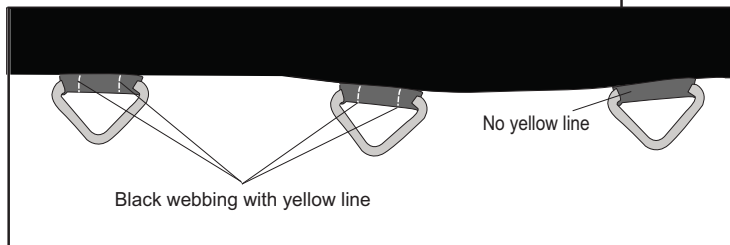
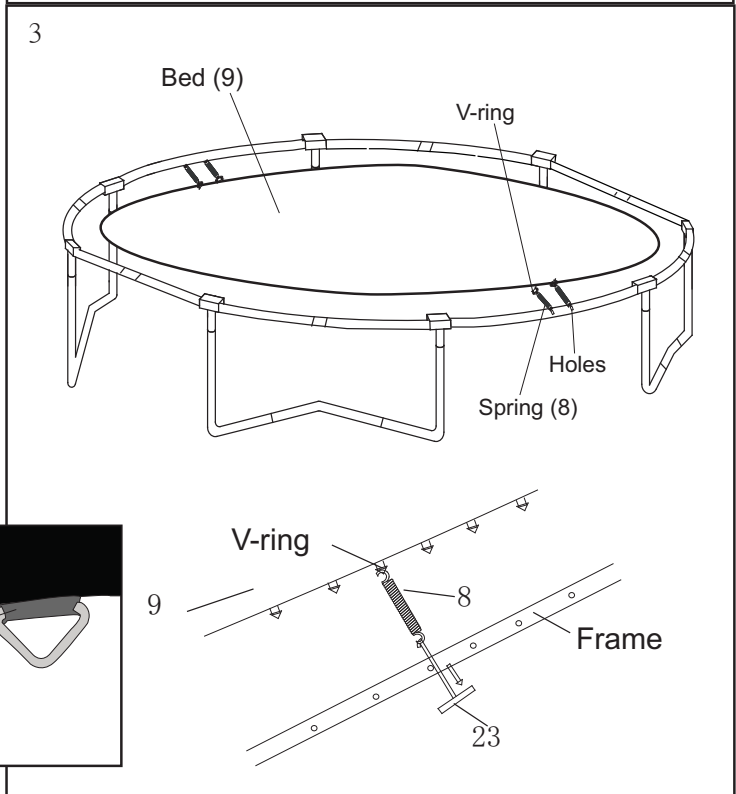

Hook a Spring (8) into one of the of the V-rings on the Bed(9) and into one of the holes in the frame. Attach a second Spring with black webbing with yellow line location directly across the Bed from the first Spring. Attach two more Springs with black webbing with yellow line location halfway between the first two springs, so four Springs are attached as shown. Attach four more Springs (not shown) halfway between the first four Springs. Continue attaching Springs halfway between the previously attached Springs, until all the Springs are attached.

During the installation of springs, wear gloves and protective eye wear.

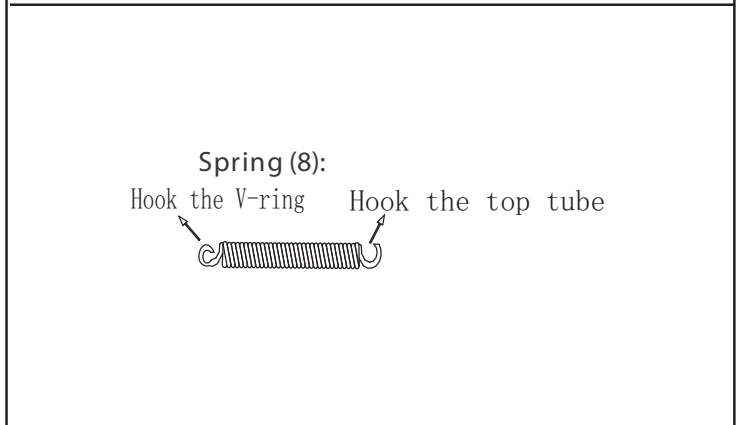

- Lay the Frame Pad (10) on the frame. Adjust the position of the Frame Pad

Do not use the trampoline without the Frame Pad (10), which is designed to reduce the likelihood of injury to the user from coming in contact with the trampoline frame. If you do not have a Frame Pad, call our Customer Hot Line toll-free at 03 9706 4475, Monday-Friday, 8 a.m. - 5 p.m. Central Time. (Excluding Holidays) Properly install the Frame Pad before using the trampoline.

- Once the frame pad is laid in the correct position on the frame, there will be two types of straps to secure the pad. Circle the frame in a clockwise position and be sure to attach all straps. See the picture for the types of straps and their attachment direction.

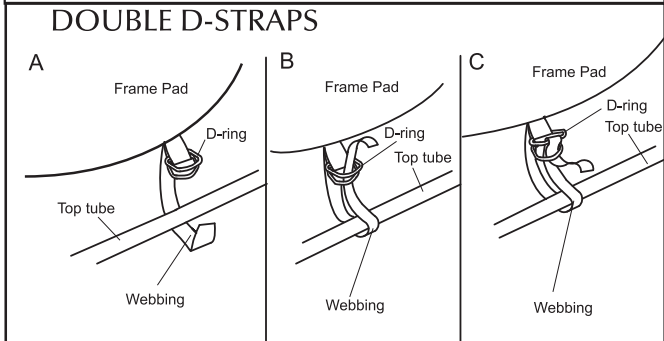
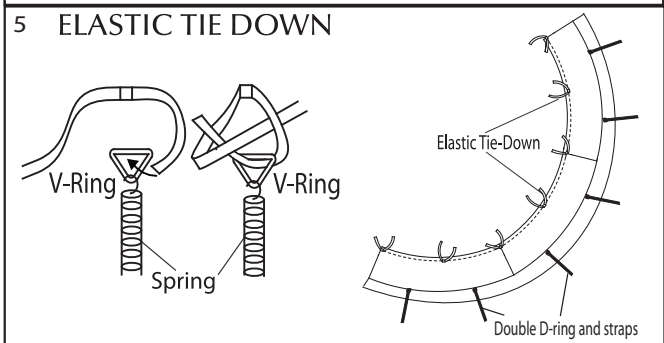
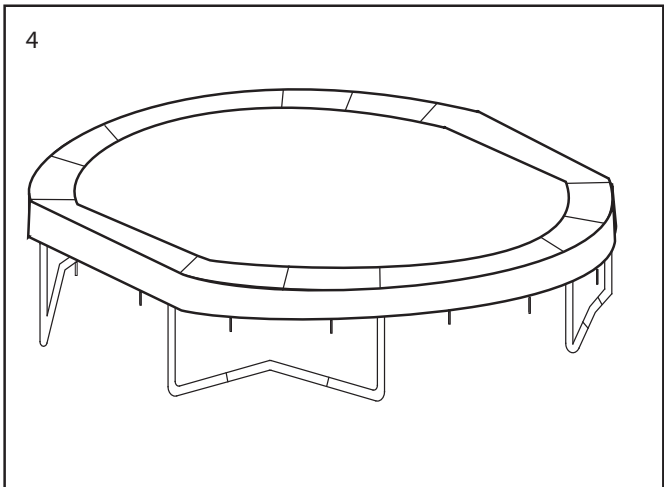

- Using the included plastic tie, attach the Safety Placard (25) to the frame near the point where jumpers will climb onto and off the trampoline. The trampoline is now fully assembled. Make sure that all parts are securely attached. Familiarize yourself and all users of the trampoline with the safety precautions, use and instructional materials, and care and maintenance instructions in this manual before using the trampoline.

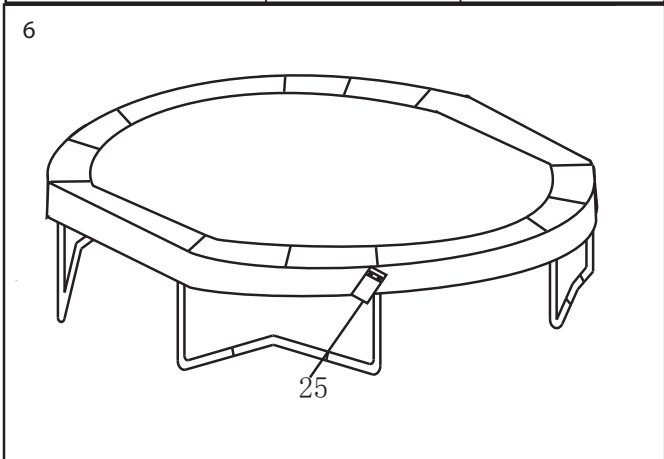

DO NOT USE TRAMPOLINE WITHOUT ENCLOSURE

7. Loosen the straps (not shown) on the underside of the frame pad (for clarity, the frame pad is not shown in steps 8 and 9). Do not remove the frame pad from the trampoline.

See the inset drawing.

Slide a U-bolt bracket (16) onto the U-bolts(11) , then thread locknuts (13) two turns onto the U-bolts.

Repeat this step on the other seven leg sections (not shown).

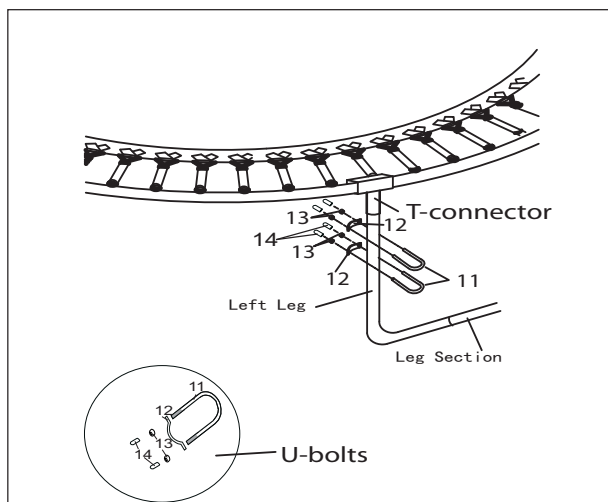

8. Lay a Straight pole(16) and a Curve pole (17) with Plastic Cap on the ground.

Make sure that the Straight pole (16) is oriented so the small holes are in the position shown. Slide a Foam Sleeve (18) onto each of the tubes; note that the ends of the Straight pole (16) should not be covered.

Insert the Straight pole (16) into the Curve pole(17).

Tighten a Self-tapping Screw (22) into the small hole in the poles (16,17).

Assemble the remaining Straight poles (16), Curve poles (17) and Foam Sleeves (18) in the same way.

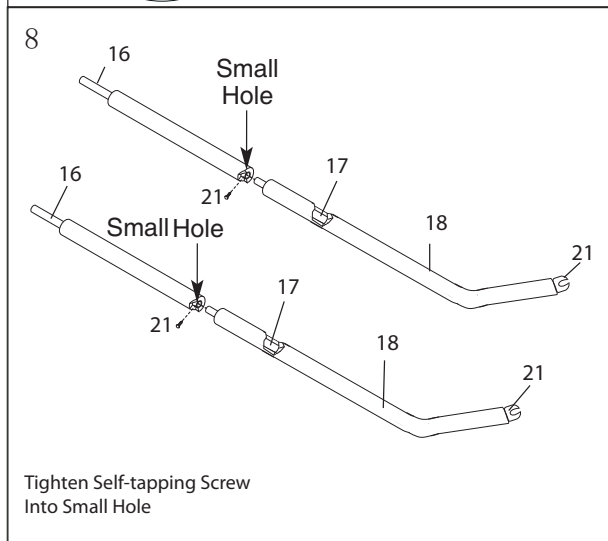

9. See inset drawing.

Slide a Steel WEDGE(15) onto the Straight Tube (16), and align the Steel WEDGE(15) between the two U-bolts (11). Next, slide one of the U-bolts (11) up until it touches the bottom of the T- connector, and tighten the two Locknuts(13) on the U-bolt. Slide the other U-bolt up until it is 2" above the lower end of the Straight tube(16), and tighten the two Locknuts(13) on the U-bolt(11). Then, press two U-bolt Plastic Caps(14) onto each U-bolt.

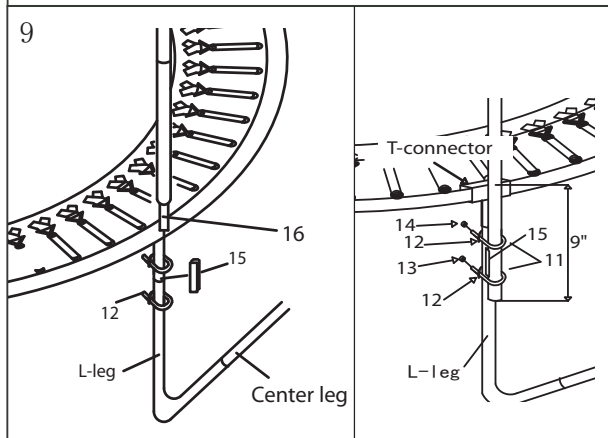

10. Attach the other seven poles(16 & 17) in the same way (See inset drawing).

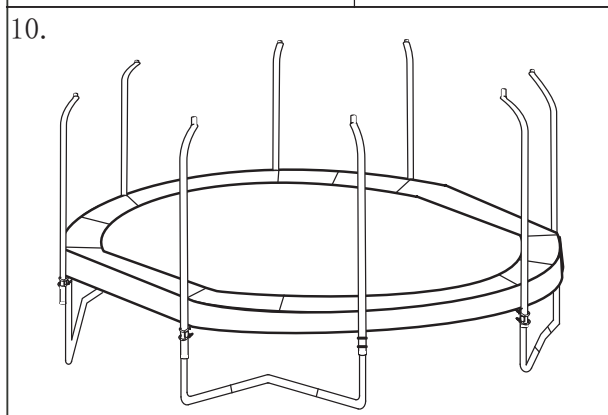

11. Lay out Top G3 Pole (19), joint each section Connector to a straight line as shown.

Assemble the remaining Top G3 Pole (19) in the same way.

Spread the Netting (20) on the trampoline bed, insert a Top G3 Pole (19) into the opening of Top Sleeve on the Netting (20). Insert the other Top G3 Pole (19) into the opposite opening of Top Sleeve on the Netting (20).

12. Joint each end of Top G3 Pole (19) by the clip of connector at each opening. The Top Sleeve of the Netting (20) become a round shape.

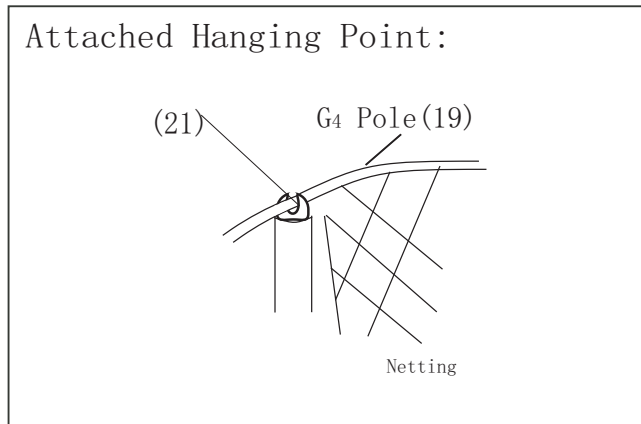
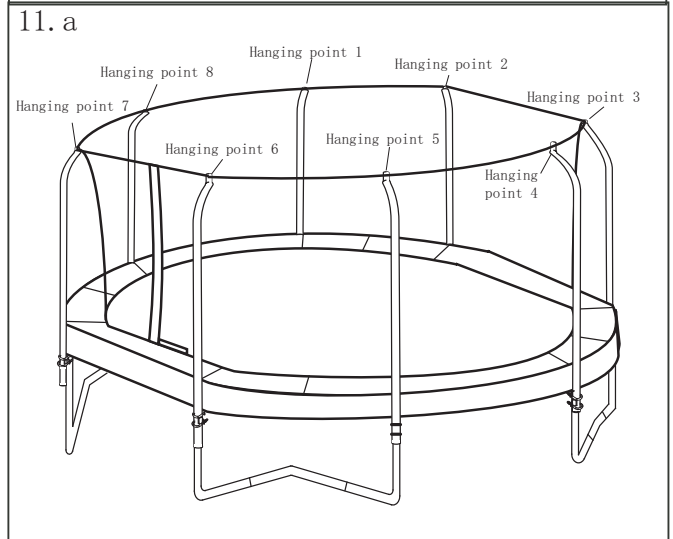
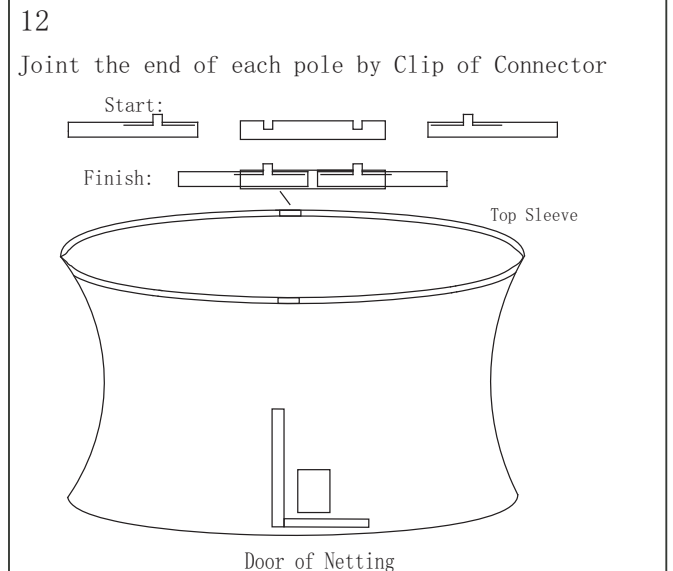
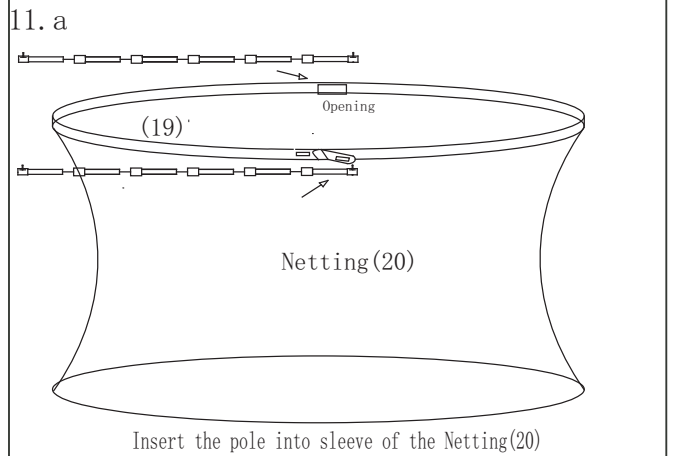
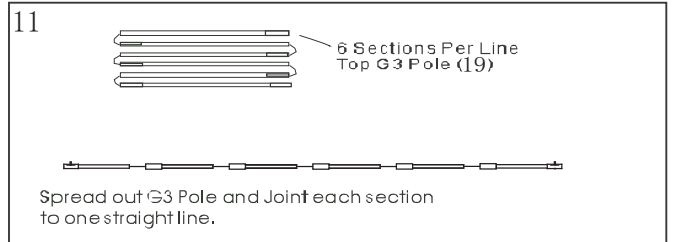

13. Note: During steps 14 and 15, you will “sew” the lower edge of the Netting(20) to the V-rings on the bed using the Cords(24).

Locate the V-ring closest to the door. Thread one end of a Cord(24) through the lower edge of the Netting(20) above the V-ring and then thread the Cord through the V-ring. Tie the Netting to the V-ring, by making a double knot in the Cord.

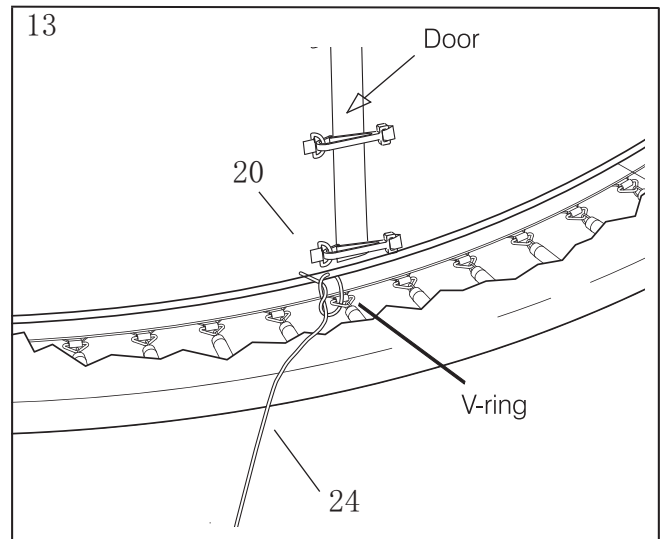

14. Thread the Cord(24) through the lower edge of the Netting(20) halfway between the first V-ring and the V-ring to the left, and then thread the Cord through the V-ring to the left. Repeat this procedure until the entire Cord is threaded through the Netting and the V-rings as shown. Keep the Cord taut. Tie the end of the Cord to the last V-ring that it reaches.

Tie a second Cord(not shown)to the last V-ring reached by the first Cord. Thread the second Cord through the Netting(20) and the V-ring as described above. Repeat this procedure with the remaining Cords until the last Cord reaches the first Cord. (Note: The last Cord may overlap the first Cord.) Make sure that the Netting is sewn to every V-ring on the trampoline bed; the Netting below the door must also be sewn to the V-rings.

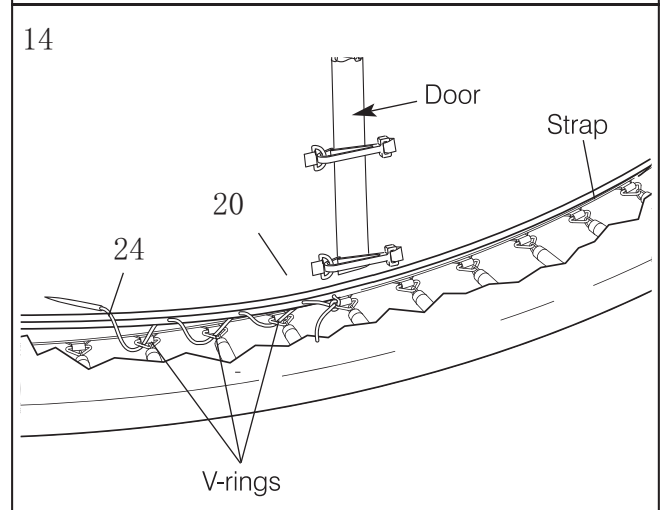

15. Using the included plastic tie,attach the Safety Placard(25) to the Netting(20) near the door as shown.

The trampoline/enclosure is now fully assembled. Make sure that all parts are securely attached. Familiarize yourself and all users of the trampoline/enclosure with the safety precautions, use and instructional materials, and care and maintenance instructions in this manual before using.

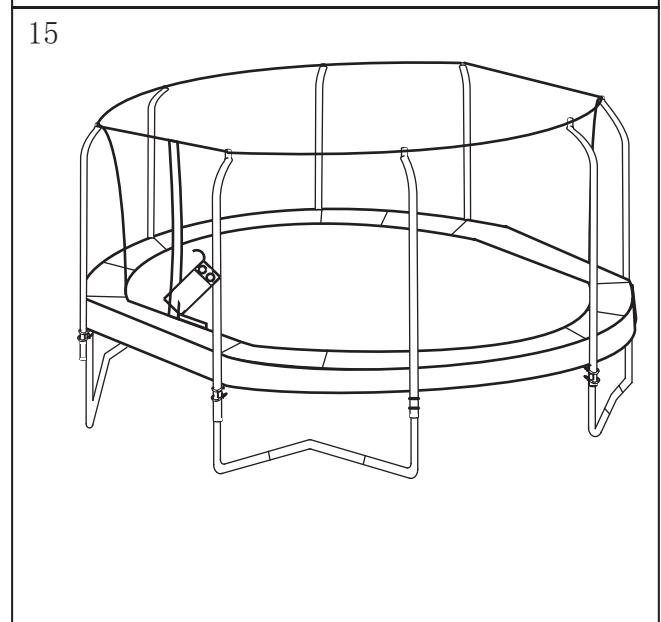

Disassembly

To disassemble the trampoline/enclosure, follow assembly steps 1 through 14 in reverse order. Do not attempt to disassemble any trampoline frame components before the springs and the bed have been removed. Use gloves to protect your hands from pinch points during disassembly.

CARE AND MAINTENANCE

CARE

Do not allow pets or animals on the trampoline or inside the enclosure, as claws may snag and pull the bed material or damage the frame pad or netting.

The trampoline/enclosure is intended to be used by one person at a time weighing 90 kg (200 lbs.) or less. The user should be either barefoot, wearing socks, or wearing gymnastic shoes.

Street shoes or tennis shoes should not be worn on the trampoline. The user should remove all sharp objects from his or her person that may cause injury or damage to the bed. Heavy, sharp, or pointed hard objects should not contact the bed.

Appropriate shoes should be worn inside the enclosure to reduce wear to the bed.

MAINTENANCE

Your trampoline is manufactured using quality materials and crafted to provide you and your family with many years of enjoyment and exercise. Proper maintenance and care will help to prolong the life of the trampoline and reduce the possibility of injury.

Prolonged exposure to the sun, especially ultraviolet rays, will shorten the life of the trampoline/enclosure fabric. For longer fabric life store the trampoline/enclosure when it is not being used. A dry trampoline/enclosure, properly stored, will provide the longest life of the fabric, sewing, and hardware. **Remove the enclosure from the trampoline during harsh weather conditions or during long periods of non-use**

The following guidelines should always be observed.

Inspect the trampoline/enclosure before each use, and replace any worn, defective, or missing parts. The following conditions could represent potential hazards and increase the danger of personal injury:

- a missing, improperly positioned, or insecurely attached frame pad, netting, enclosure tubes, foam sleeves
- punctures, frays, tears, or holes worn in the bed, frame pad, netting, foam sleeves.
- deterioration in the stitching or fabric of the bed, frame pad, netting
- ruptured or missing springs
- a bent or broken frame, leg, enclosure tubes
- a sagging bed, netting
- sharp protrusions on the frame, suspension system, enclosure tubes

If any of these conditions exists, the trampoline should be disassembled or otherwise protected against use until the condition is remedied.

REMOVING AND STORING THE TRAMPOLINE/ENCLOSURE

Make sure that the trampoline/enclosure is dry before removing and storing it. Use caution while removing the tubes due to the weight of the tubes.

Once the enclosure is removed from the trampoline, remove all items from the trampoline bed. Make sure that the bed is clean and that it has no tears or holes. Store the trampoline/enclosure in a safe, dry location.

SPECIAL CONSIDERATIONS

High Wind

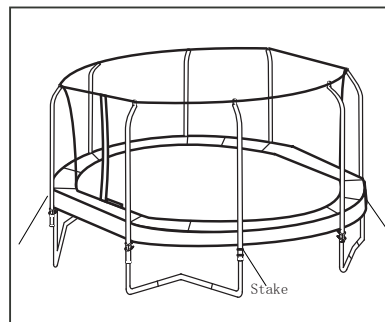

It is possible for the trampoline/enclosure be blown about by high wind. If you anticipate high winds, the trampoline/enclosure should be moved to a sheltered location, disassembled, or tied down to the ground with ropes and stakes (not included). At least three ropes and three stakes should be used. The tops of the stakes should be at ground level so that they will not create a tripping hazard. In addition, the tops of the stakes should be covered, if necessary, so that users will not be injured by falling onto the stakes. Make sure to attach the ropes to the top of the frame; **do not simply secure the legs or the bases to the ground, as they can separate from the frame sockets.**

Moving the Trampoline

If the trampoline/enclosure needs to be moved, it should be moved by two persons, kept horizontal, and lifted slightly. If necessary, the trampoline/enclosure can be disassembled for moving.

To disassemble the trampoline/enclosure, follow the assembly steps in reverse order (see pages 15 to 20). Do not attempt to disassemble the frame sections, legs, or bases before the bed and springs have been removed.

EXPLODED DRAWING AND PART LIST

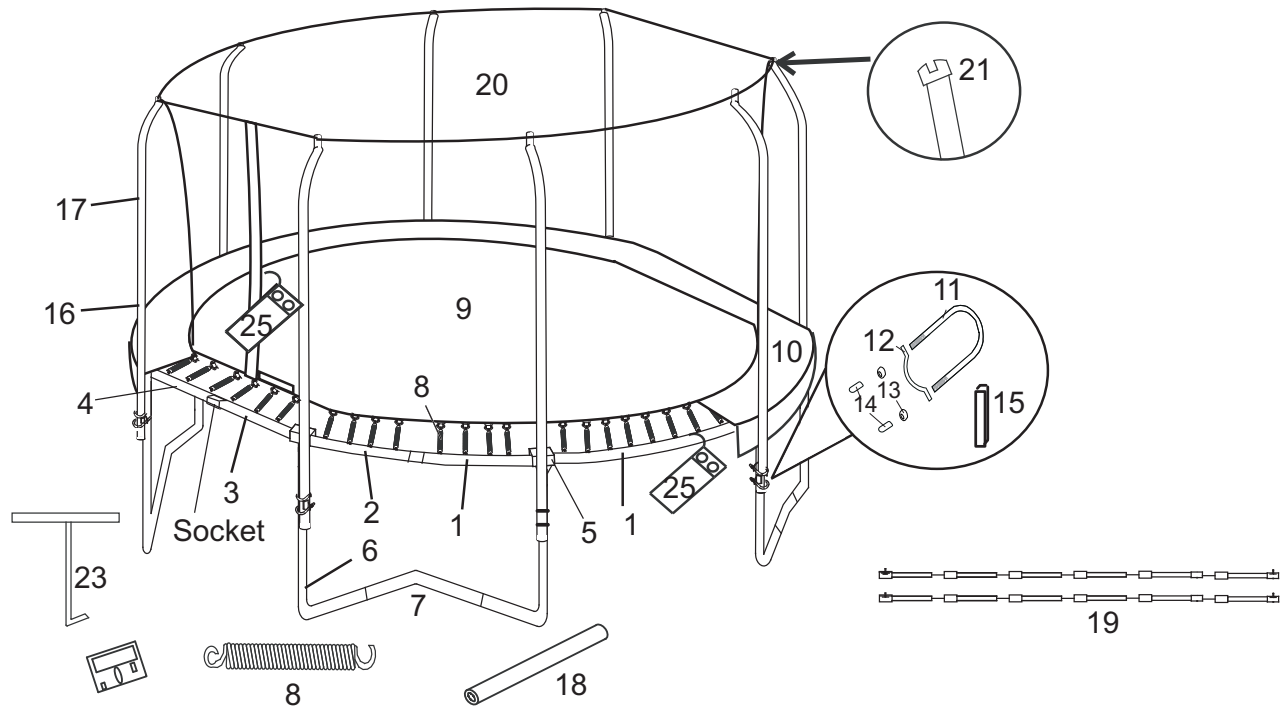

Key No.	Qty.	Description	Key No.	Qty.	Description
1	6	Top Tube (A, with T-connector)	15	8	Steel WEDGE
2	4	Top Tube (B, with Socket)	16	8	Straight Poles
3	2	Straight Top Tube (C, with T-connector)	17	8	Curve Poles
4	2	straight Top Tube (D, with socket)	18	16	Foam Sleeves
5	8	T-connector	19	2	G3 Poles
6	8	L-leg	20	1	Netting with attached hardware
7	4	Center Leg	21	8	Plastic Cap (This part has been attached to the top of Curve poles(18).)
8	76	Springs	22*	24	Self-tapping screw
9	1	Stitched Bed with V-ring	23	1	Spring pulling tool
10	1	Frame Pad	24*	8	Cord
11	16	U-bolt	25	1	User's Manual and Safety Placard (2pcs)
12	8	U-bolt Bracket	*	1	Set of ASTM Frame Labels
13	32	Locknut			
14	32	U-bolt Plastic Cap			

*This part is not illustrated.
Specifications are subject to change without notice.

ORDERING REPLACEMENT PARTS

To order replacement parts, visit our Web site or call our Customer Hot Line (see page 3). To help us assist you, please provide the following information when calling:

- the MODEL of the trampoline/enclosure
- the NAME of the product
- the KEY NUMBER and DESCRIPTION of the part (see the PART LIST above)
- the quantity needed
- the desired method of shipping