

# BAZOOINGI

## PROJUMP Enclosure system

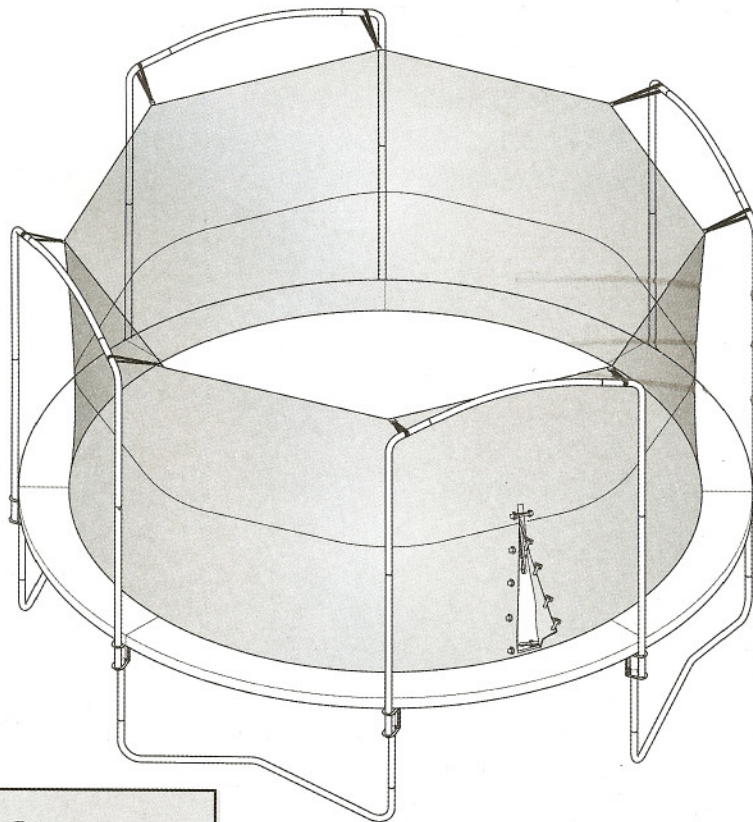

**⚠ WARNING**

Read the assembly, installation, care, maintenance, and use instructions in this manual prior to assembling and using this trampoline enclosure. Save this manual for future reference.

**USER'S MANUAL ..... 3**

## QUESTIONS?

If you have questions after reading this manual, please call our toll-free Customer Hot Line. The trained technicians on our Customer Hot Line will provide immediate assistance.

Customer Hot Line: 1-877-927-8777  
Monday–Friday, 8 a.m.–5 p.m.

## REPLACEMENT PARTS

[www.bazoongi.com](http://www.bazoongi.com)

# BAZOOINGI

## PROJUMP

### Enclosure system

## CONTENTS

IMPORTANT PRECAUTIONS .....	4
WARNING PLACARD PLACEMENT .....	5
BEFORE YOU BEGIN .....	6
TRAMPOLINE ENCLOSURE SAFETY INFORMATION .....	6
ASSEMBLY .....	8
CARE AND MAINTENANCE .....	12
EXPLODED DRAWING AND PART LIST .....	13
ORDERING REPLACEMENT PARTS .....	13

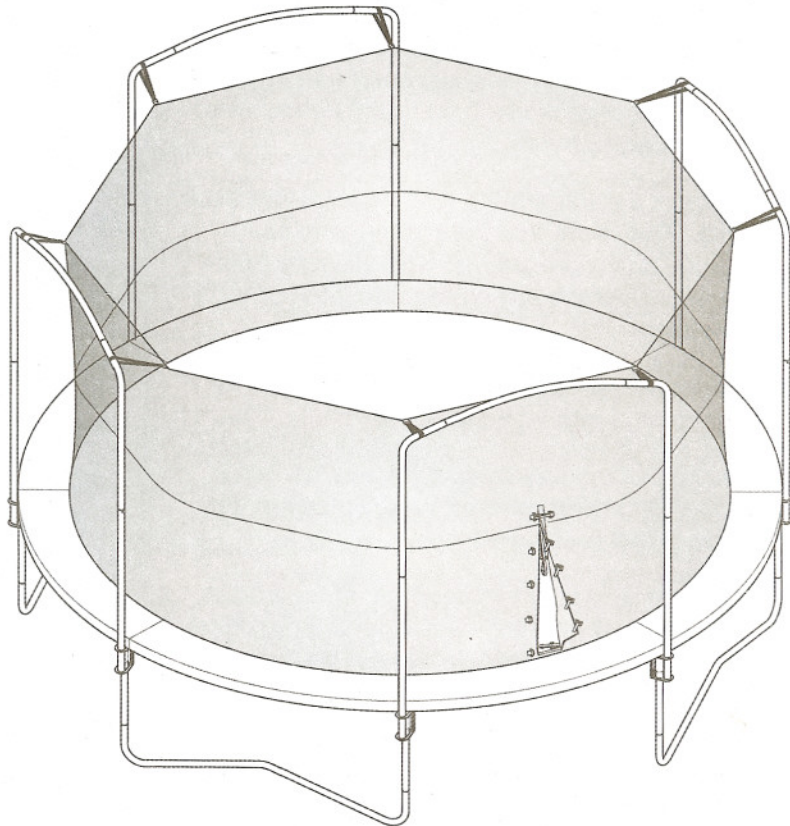

# IMPORTANT PRECAUTIONS

**⚠ WARNING:** To reduce the risk of serious injury, read and follow all warnings, precautions, and instructions in this manual before assembling and using the trampoline enclosure.

1. The owner and supervisors of the trampoline and enclosure are responsible to make all users aware of practices specified in this manual.
2. The trampoline enclosure is to be used only as an enclosure for a round trampoline.
3. Place the trampoline and enclosure on a level surface before use.
4. Adequate overhead clearance is essential. A minimum of 7.3 m (24 ft.) from ground level is recommended. Provide clearance for wires, tree limbs, and other possible hazards.
5. Lateral clearance is essential. Place the trampoline and enclosure away from walls, structures, fences, and other play areas. Maintain a clear space on all sides of the trampoline and enclosure.
6. Use the trampoline and enclosure in a well-lighted area. Artificial illumination may be required for shady areas.
7. Secure the trampoline and enclosure against unauthorized and unsupervised use. If an access ladder is used, it should be removed when the trampoline is not in use.
8. Inspect the trampoline enclosure before each use. Make sure that the netting, enclosure tubes, and foam sleeves are correctly positioned. Replace any worn, defective, or missing parts.
9. Remove any obstructions from beneath the trampoline and enclosure.
10. Do not attach anything to the netting that is not a manufacturer-approved accessory or part of the enclosure.
11. Bounce only when the surface of the bed is dry. Wind or air movement should be calm to gentle. The trampoline must not be used in gusty or severe winds.
12. The trampoline enclosure is designed for users weighing 90 kg (200 lbs.) or less. The enclosure is not recommended for use by children under 6 years of age.
13. Do not allow more than one person inside the trampoline enclosure. Use by more than one person at the same time can result in serious injury.
14. Wear clothing free of drawstrings, hooks, loops, or anything that could get caught in the netting.
15. Do not jump on the trampoline while holding or having an object, particularly one that is sharp or breakable.
16. Do not use the trampoline enclosure while under the influence of alcohol or drugs. These substances impair reaction time, judgment, and physical coordination.
17. Use the trampoline enclosure only with mature, knowledgeable supervision.
18. Misuse and abuse of the trampoline enclosure is dangerous and can cause serious injuries.
19. Climb onto and off the trampoline. Do not jump onto it or off it. Do not use the trampoline as a springboard to other objects.
20. Enter and exit the trampoline enclosure only at the door designated for that purpose.
21. Do not attempt to crawl under the netting.
22. Do not attempt to jump over the netting.
23. Do not intentionally rebound off the netting.
24. Do not hang from, kick, cut, or climb on the netting.
25. The trampoline frame and the enclosure frame are made of metal. They are not grounded, and they will conduct electricity. Therefore, an electrocution hazard exists. Lights, electric heaters, extension cords, and household electrical appliances are not permitted in or on the trampoline or enclosure.

26. The trampoline is a rebounding device that propels the user to unaccustomed heights and into a variety of body movements. Rebounding off the trampoline, striking the frame or springs, or improperly landing on the bed may cause injury.
27. Do not attempt or allow somersaults. This can result in a broken head, neck, back, or leg. Landing on the head or neck can cause serious injury, paralysis, or death, even when landing in the middle of the bed.
28. Jumpers who lose control of their jump may land on the bed incorrectly, land on the frame

or springs, or fall off the trampoline. Attempting maneuvers beyond present skill levels increases the chance of losing control.

29. Injury may result from encountering the frame or falling through the springs while getting onto or off the trampoline or while jumping. Stay in the center of the bed when jumping. Do not use the trampoline without the frame pad securely in place to cover the frame. The frame pad is not designed or intended to support the weight of the user. Do not step or jump directly onto the frame pad.

## WARNING PLACARD PLACEMENT

The placard shown at the right must be attached to the trampoline enclosure by the owner (see assembly step 7 on page 11). If the placard is missing or illegible, call our Customer Hot Line toll-free at 1-877-927-8777, Monday through Friday, 8 a.m. until 5 p.m. Central Time, to order a free replacement placard. Note: The placard is not shown actual size.

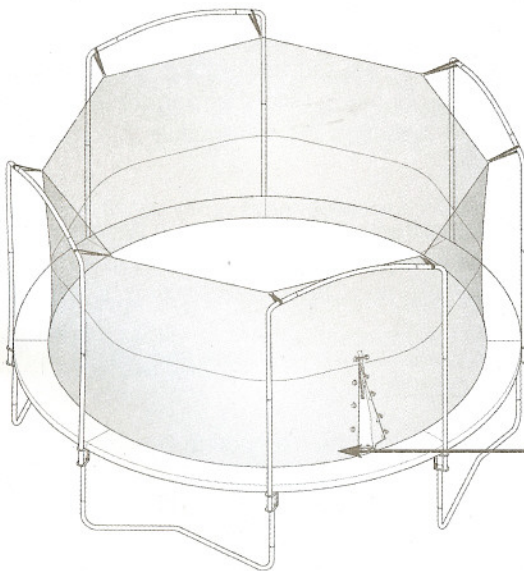

### TRAMPOLINE ENCLOSURE SAFETY INSTRUCTIONS

#### ⚠ WARNING



Do not land on head or neck. Paralysis or death can result, even if you land in the middle of the trampoline mat (bed).

To reduce the chance of landing on your head or neck, do not do somersaults (flips).



Only one person at a time in the trampoline enclosure.

This trampoline enclosure system is not recommended for use by children under 6 years of age.

Multiple jumpers increase the chances of loss of control, and this can result in broken head, neck, back, or leg.

#### For the Supervisor

Inspect the trampoline before using. Keep frame pad in place. Do not use when trampoline is wet or in a windy condition. A worn or damaged mat (bed), spring, or frame piece should be replaced immediately.

Keep objects away that could interfere with the jumper.

Secure the trampoline against unauthorized and unsupervised use.

Use trampoline enclosure only with mature, knowledgeable supervision. Enforce all safety rules and be familiar with the information in the User's Manual to help users in following trampoline enclosure instructions and trampoline safety.

Do not exceed the weight limit recommended by the manufacturer.

Use only when the enclosure barrier has no holes, pole clamps are tightly secured to the poles, and the support (frame), and the barrier is properly suspended.

Do not intentionally rebound off the barrier. Do not hang from, kick, cut, or climb on the barrier.

Wear clothing free of drawstrings, hooks, loops, or anything that could get caught in the barrier.

Do not attach anything to the barrier that is not a manufacturer approved accessory or part of the enclosure system.

#### For the Jumper

Do not use the trampoline enclosure system when under the influence of drugs or alcohol.

##### Jumping

Learn fundamental jumps and body positions thoroughly before trying more advanced skills. Review the User's Manual to learn about how to do basic jumps.

Stop your bounce by flexing your knees as your feet come in contact with the trampoline mat (bed).

Avoid jumping too high or for too long. Always control your jump. A controlled jump is one where the take off and land spots are the same.

Bounce in the center of the trampoline. Focus your eyes on the trampoline mat (bed). Failure to do so may result in a loss of balance and control.

Do not jump from other objects, building or surfaces onto the trampoline, or into or over the trampoline enclosure.

##### Getting on and off

Climb on and off the trampoline at the enclosure door or barrier opening. Do not jump on or off. Do not crawl under the barrier. Do not use the trampoline as a springboard to other objects.

For skill training information, contact a trainer certification organization.

**ATTACH TO NETTING AT DOOR**

Made In China

---

## BEFORE YOU BEGIN

Thank you for selecting a Bazoongi trampoline enclosure. The enclosure, when combined with a properly placed and maintained trampoline, will provide many years of backyard fun. Your trampoline enclosure comes equipped with warnings and instructions for the assembly, care, maintenance, and use of the enclosure. This information must be read by all trampoline supervisors and users before any person is allowed to use the enclosure on a trampoline.

If you have questions after reading this manual, please call our toll-free Customer Hot Line at 1-877-927-8777, Monday through Friday, 8 a.m. until 5 p.m. Central Time (excluding holidays). To help us assist you, please mention the name of the product when calling (Bazoongi Enclosure).

---

## TRAMPOLINE ENCLOSURE SAFETY INFORMATION

### NEED FOR TRAMPOLINE ENCLOSURE SAFETY

A trampoline enclosure is a recreational product.

The information on this page and on page 7 identifies important safety precautions. The precautions are not all-inclusive, because an enclosure can be used in ways that this manual cannot cover completely.

To prevent pinches and cuts during enclosure use, a frame pad must be installed on the trampoline. (See the trampoline manufacturer's instructions.) The frame pad must be installed before the enclosure is erected. The frame pad reduces the chance of injury from accidental contact with the springs and frame.

### USING THE ENCLOSURE SAFELY

#### Adult Supervision of Children

Children using a trampoline with a trampoline enclosure must be supervised by adults. Young children must be supervised constantly. Adults must pay particular attention to:

- things that children bring into the enclosure.
- children's activities inside the enclosure.
- conditions inside the enclosure while children are using it.
- the way children get into and out of the enclosure.

Additional details of safe enclosure use are described below.

#### Electrocution Hazard Associated with the Metal Frame of the Trampoline and Enclosure

The trampoline and enclosure frames are made of metal. They are not grounded, and they will conduct

electricity. Lights, electric heaters, extension cords, and household electrical appliances are not permitted in or on the trampoline or enclosure.

#### Hazards Associated with Entering and Exiting the Trampoline Enclosure

A trampoline enclosure installed on a trampoline is raised off the ground. The height of the enclosure increases the risk of a fall when a jumper is entering or exiting the enclosure. Young children in particular may have difficulty getting into and out of the enclosure. To reduce the risk of falling, help young children to get into and out of the enclosure.

Enter and exit the trampoline enclosure only through the door of the enclosure (the opening in the netting walls). The trampoline bed and the netting walls of the enclosure are separate pieces; jumpers, particularly young children, must not exit the enclosure by going out between the bed and the netting walls. Trying to exit in this way poses a risk of strangulation from being caught between the trampoline frame and the netting walls.

Darkness increases the chances of a fall when a jumper is entering or exiting the enclosure. Do not use the trampoline unless adequate lighting is provided.

#### Hazards Associated with Animals and Sharp and Breakable Objects

To avoid damage to the trampoline enclosure and the trampoline, do not allow pets or other animals inside of the enclosure. The claws and teeth of animals can damage the netting. Do not jump on the trampoline while holding or wearing a sharp or breakable object.

## Hazards Associated with High Winds

A trampoline with an enclosure can be moved or blown over by high winds, potentially injuring anyone in its path or anyone inside of the enclosure. If you anticipate high winds, take down the enclosure netting, and stake the trampoline frame to the ground (see page 12), or move the trampoline and enclosure to a sheltered location.

## Storing the Trampoline Enclosure Safely

Specific steps for storing the trampoline enclosure are presented later in this manual. There are specific safety precautions to be aware of when storing the enclosure.

Remove the attached tube sections as a unit, and separate them on the ground. Avoid pinching your fingers by keeping your fingers away from pinch points near the bracket assembly while you are removing the tubes from the frame.

## Placing the Trampoline in a Safe Place

There must be at least 7.3 m (24 ft.) of clear, open space above the trampoline bed. Do not place or store anything underneath the trampoline.

To avoid injury, the trampoline must be kept away from objects and possible hazards including electric power wiring, tree limbs, and fences. Do not place the trampoline near any other recreational devices or structures such as a swimming pool or swing set.

The trampoline must be placed on a level surface before use, and the area around the trampoline must always be well lighted.

## For the Supervisor

Be familiar with the information in this manual and enforce all of the safety rules. Help new users and all users to use the trampoline and enclosure safely.

All trampoline users must have someone watch them, regardless of the skill or age of the user.

Secure the trampoline against unauthorized and unsupervised use. Keep the trampoline free of objects that could interfere with the jumper.

This trampoline enclosure is not recommended for use by children under 6 years of age or by anyone weighing more than 90 kg (200 lbs.).

Use the trampoline only when the bed is clean and dry. Inspect the trampoline and enclosure prior to each use and replace any worn or damaged parts. Use only when the enclosure netting has no holes, the clamps are tightly secured to the tubes and the frame, and the netting is properly suspended.

## For the Jumper

Do not use the trampoline enclosure when under the influence of drugs or alcohol.

Avoid jumping too high or for too long. Always control your jump.

Take turns jumping one at a time, and always have someone watch you.

Do not attempt to jump over the netting. Do not intentionally rebound off the netting. Do not hang from, kick, cut, or climb on the netting.

Wear clothing that is free of drawstrings, hooks, loops or anything that could get caught in the netting.

Do not attach anything to the netting that is not a Bazoongi approved accessory or part of the trampoline enclosure.

## How to Enter and Exit the Trampoline Enclosure

Enter and exit the trampoline enclosure only through the door in the netting. To enter the enclosure, first unfasten the plastic clips on the door and unzip the zippers. Place one knee on the frame pad and climb head first through the door. Refasten the plastic clips and close the zippers.

To exit the enclosure, first unzip the zippers on the door and unfasten the plastic clips. Sit on the bed of the trampoline and climb feet first through the door. When you are through the door and sitting on the frame pad, step or jump safely to the ground. Close the zippers and refasten the plastic clips.

# ASSEMBLY

## IMPORTANT ASSEMBLY INFORMATION

- Assembly requires a 7/16" socket and ratchet (or a 7/16" open-end wrench) and a Philips screwdriver (not included).
- Assembly requires two adults. Keep children away from the trampoline enclosure until it is fully assembled.
- Use gloves to protect your hands from pinch points during assembly.
- Make sure that the trampoline is properly assembled, with the frame pad properly attached, before you assemble the trampoline enclosure.
- The assembly steps refer to parts by their descriptions and key numbers (see the PART LIST on page 13).
- See the EXPLODED DRAWING AND PART LIST on page 13 and make sure that all listed parts are included. If a part is missing, see ORDERING REPLACEMENT PARTS at the bottom of page 13.

## TRAMPOLINE PLACEMENT

1. Place the trampoline and enclosure on a level surface before use.
2. Adequate overhead clearance is essential. A minimum of 7.3 m (24 ft.) from ground level is recommended. Provide clearance for wires, tree limbs, and other possible hazards. Lateral clearance is also essential. Place the trampoline and enclosure away from walls, structures, fences, and other play areas. Maintain a clear space on all sides of the trampoline and enclosure.
3. Use the trampoline and enclosure in a well-lit area. Artificial illumination may be required for shady areas.
4. Secure the trampoline and enclosure against unauthorized and unsupervised use.
5. Remove any obstructions from beneath the trampoline and enclosure.
6. The trampoline enclosure is only to be used as an enclosure for a round trampoline.

1. Make sure that you understand the information in the box at the top of this page before you begin assembling the trampoline enclosure.

Loosen the straps (not shown) on the underside of the frame pad (for clarity, the frame pad is not shown in steps 1 and 3). Do not remove the frame pad from the trampoline.

See the inset drawing.

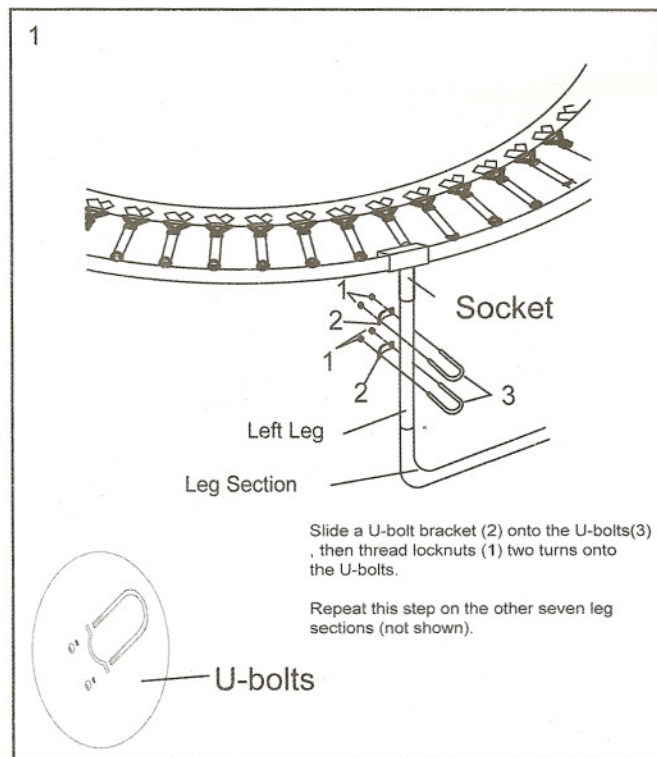

- Lay two Straight Tubes (6), two L-tubes (7), and a Curved Tube (8) on the ground so they form an arch. Make sure that the Straight Tubes are oriented so the small holes are in the positions shown. Slide a Foam Sleeve (9) onto each of the five Tubes; note that the ends of the Straight Tubes should not be covered.

Insert the two L-tubes (7) into the two Straight Tubes (6). Next, insert the two L-tubes into the Curved Tube (8).

Tighten four Self-tapping Screws (5) into the small holes in the Straight Tubes (6) and the Curved Tube (8). Note: The small holes may be on the opposite side the Curved Tube.

Assemble the remaining Straight Tubes, L-tubes, Curved Tubes, and Foam Sleeves in the same way.

- See inset drawing.

Attach the other three arches in the same way (not shown).

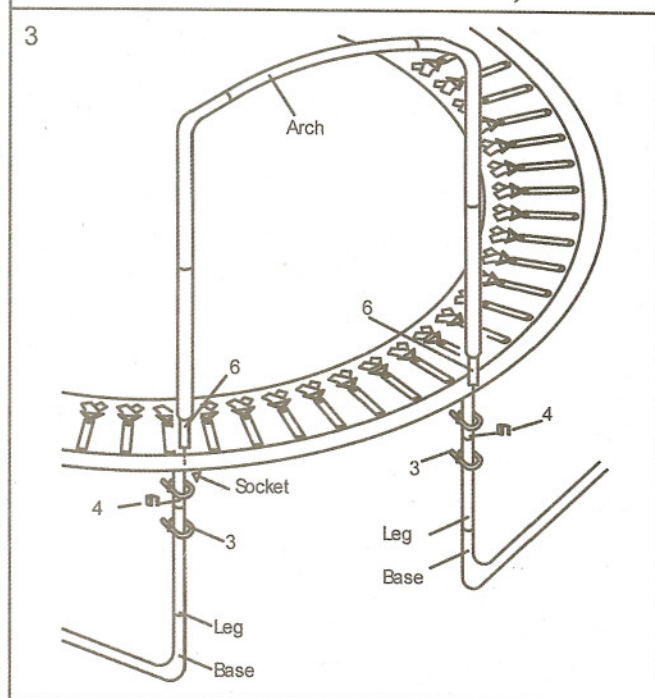
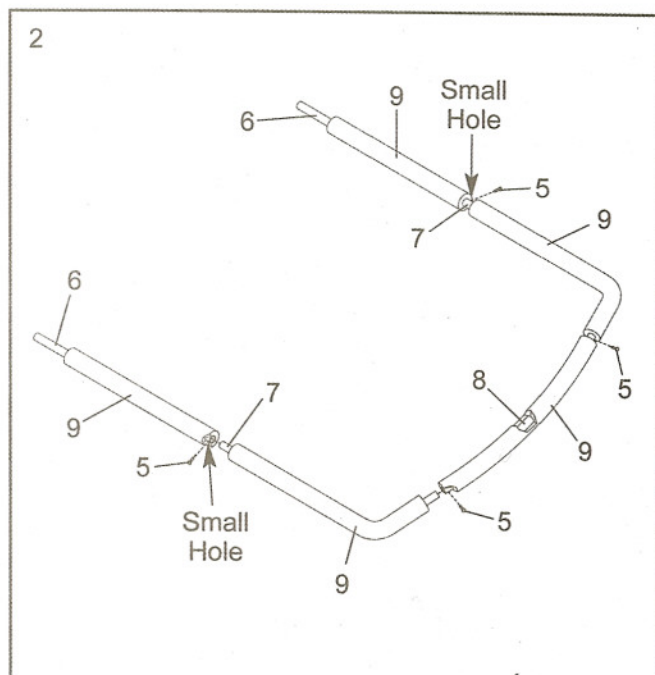

Slide a Black C-clip(4) onto the Straight Tube(6),and align the bottom of the Black C-clip with the bottom of the socket.Next, slide one of the U-bolts(3)up until it touches the bottom of the socket,and tighten the two Locknuts(1)on the U-bolt. Slide the other U-bolt up until it is 2" above the lower end of the Straight tube,and tighten the two Locknuts on the U-bolt. Then,press two Plastic Caps(11) onto each U-bolt.

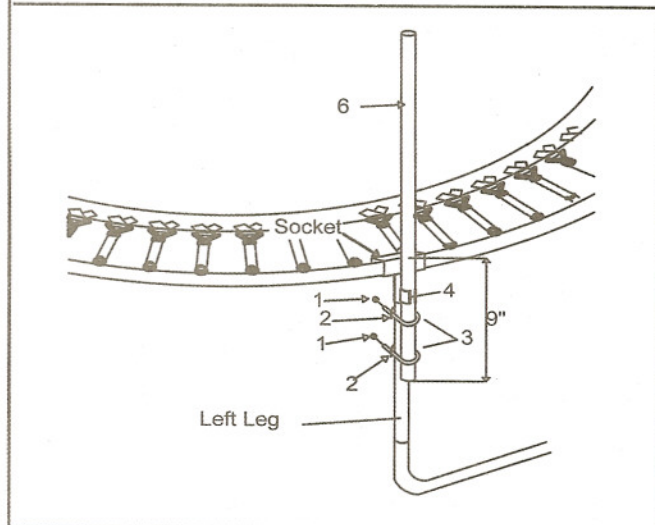



- Spread the Netting (10) on the trampoline bed, with the door of the Netting below the Curved Tube (8) where jumpers will climb onto and off the trampoline. Next, locate one of the D-rings attached to the upper edge of the Netting. Lift the D-ring and hold it near an L-tube (7) as shown.

See inset drawing A.  
See inset drawing B.  
See inset drawing C.

Pull the end of the Strap to remove any slack.

**Do not fully tighten the Strap yet.**

Attach the Netting (10) to the other seven L-tubes (7) with the other seven Straps in the same way.

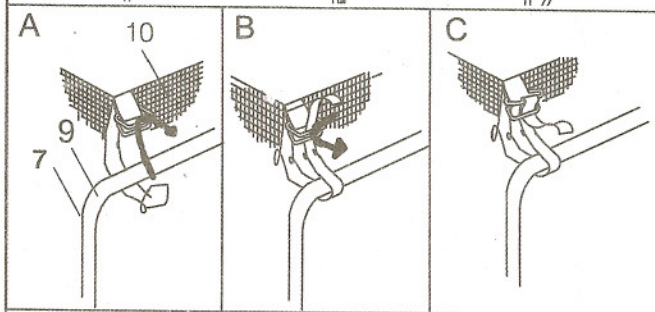
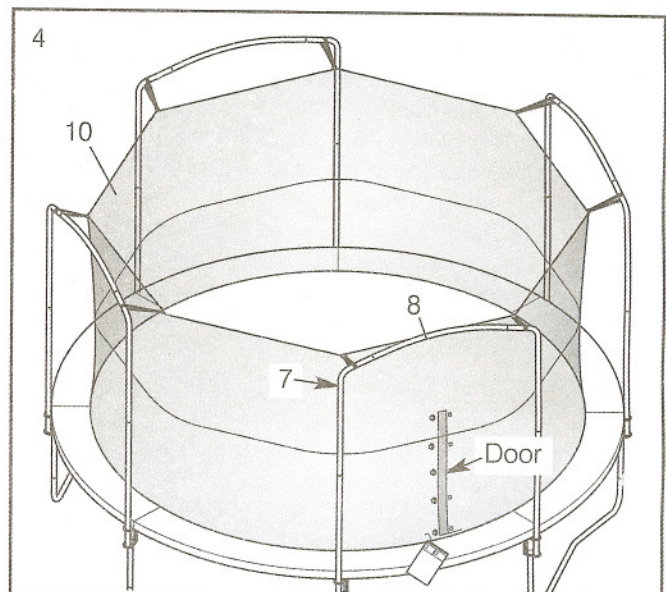

- Note: During steps 5 and 6, you will "sew" the lower edge of the Netting (10) to the V-rings on the bed using the Cords (13).

Locate the V-ring closest to the door. Thread one end of a Cord (13) through the lower edge of the Netting (10) above the V-ring and then thread the Cord through the V-ring. Tie the Netting to the V-ring, by making a double knot in the Cord. Note: If your trampoline enclosure includes a Plastic Needle (14, see the inset drawing), insert the end of the Cord into the Needle and use the Needle to thread the Cord through the Netting.

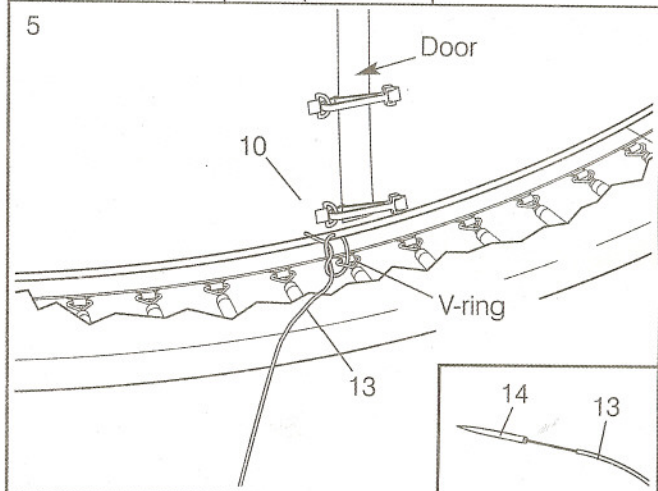

- Thread the Cord (13) through the lower edge of the Netting (10) halfway between the first V-ring and the V-ring to the left, and then thread the Cord through the V-ring to the left. Repeat this procedure until the entire Cord is threaded through the Netting and the V-rings as shown. Keep the Cord taut. Tie the end of the Cord to the last V-ring that it reaches.

Tie a second Cord (not shown) to the last V-ring reached by the first Cord. Thread the second Cord through the Netting (10) and the V-rings as described above. Repeat this procedure with the remaining Cords until the last Cord reaches the first Cord. (Note: The last Cord may overlap the first Cord.) **Make sure that the Netting is sewn to every V-ring on the trampoline bed; the Netting below the door must also be sewn to the V-rings.**

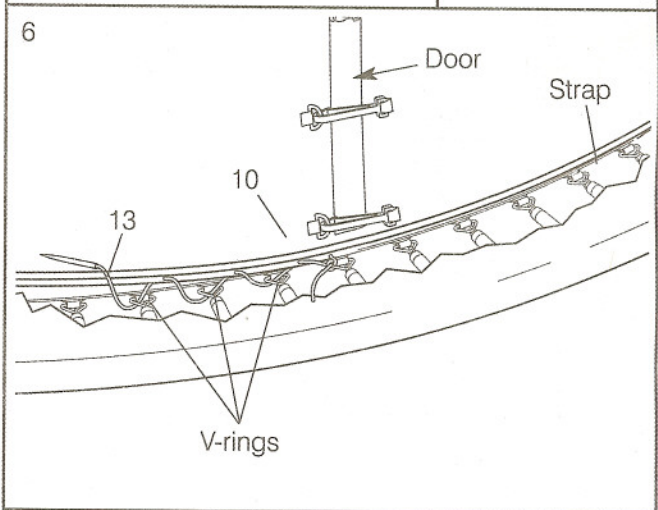

7. Tighten the eight Straps attaching the Netting (10) to the L-tubes (7) (see step 4). Tie the free end of each Strap around the rest of the Strap to prevent the Strap from loosening.

Tighten the straps (not shown) on the underside of the frame pad.

Using the included plastic tie, attach the Safety Placard (12) to the Netting (10) near the door as shown.

**The trampoline enclosure is now fully assembled. Make sure that all parts are securely attached. Familiarize yourself and all users of the trampoline and the enclosure with the safety precautions, use and instructional materials, and care and maintenance instructions in this manual before using the enclosure.**

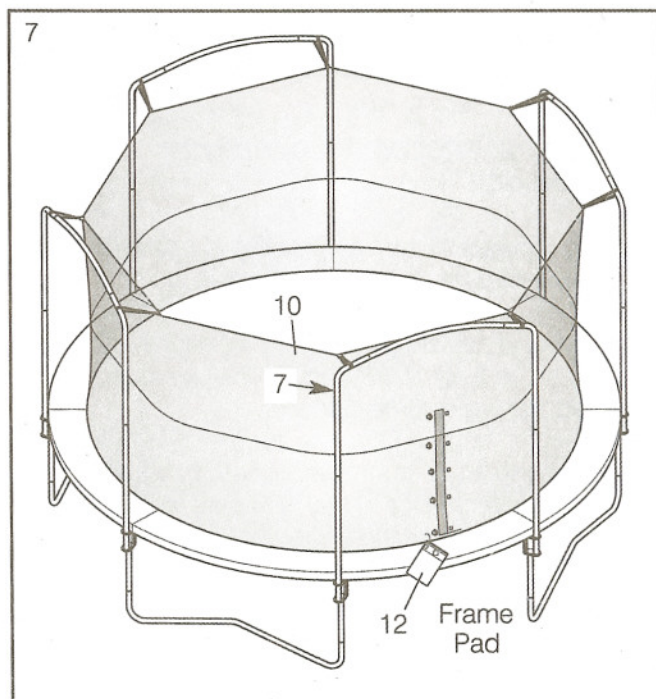

## DISASSEMBLY

To disassemble the trampoline enclosure, follow assembly steps 1 through 7 in reverse order.

# CARE AND MAINTENANCE

## TRAMPOLINE ENCLOSURE CARE AND MAINTENANCE

To avoid damage to the trampoline and enclosure, do not allow pets or animals inside the enclosure.

Appropriate shoes should be worn inside the enclosure to reduce wear to the bed. Follow the trampoline manufacturer's recommendations.

Prolonged exposure to the sun, especially ultraviolet rays, will shorten the life of the enclosure fabric. For longer fabric life, store the enclosure when it is not being used. A dry enclosure, properly stored, will provide the longest life of the fabric, sewing, and hardware. Remove the enclosure from the trampoline during harsh weather conditions or during long periods of non-use.

Inspect the trampoline enclosure before each use, and replace any worn, defective, or missing parts. The following conditions could represent potential hazards and increase the danger of personal injury:

- missing, improperly positioned, or insecurely attached netting, enclosure tubes, or foam sleeves
- punctures, frays, tears, or holes worn in the netting or foam sleeves
- deterioration in the stitching or fabric of the netting
- bent or broken enclosure tubes
- sagging netting
- sharp protrusions on enclosure tubes

**If any of these conditions exists, the trampoline enclosure should be disassembled or otherwise protected against use until the condition is remedied.**

## REMOVING AND STORING THE TRAMPOLINE ENCLOSURE

Make sure that the trampoline enclosure is dry before removing and storing it. The enclosure tubes can be removed in sections. Hold two straight tubes and loosen the U-bolts securing them. Lift the straight tubes, the attached L-tubes, and the attached curved tube out of the clamps. Lay the tubes on the ground. **Use caution while removing the tubes due to the**

**weight of the tubes and the tendency of the tubes to rotate. Store the enclosure in a safe, dry location.**

Once the enclosure is removed from the trampoline, remove all items from the trampoline bed. Make sure that the bed is clean and that it has no tears or holes.

## SPECIAL CONSIDERATIONS

### High Wind

It is possible for the trampoline and enclosure to be blown about by high wind. If you anticipate high winds, move the trampoline and enclosure to a sheltered location. Disassemble the enclosure netting. Tie the trampoline frame down to the ground using ropes and stakes (not included). **At least three ropes and three stakes should be used.** The tops of the stakes should be at ground level so that they will not create a tripping hazard. In addition, the tops of the stakes should be covered, if necessary, so that users will not be injured by falling onto the stakes. Make sure to attach the ropes to the top of the trampoline frame; do not simply secure the legs or the bases to the ground, as they can separate from the frame sockets.

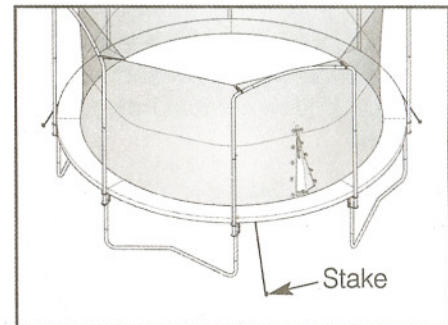

### Moving the Trampoline and Enclosure

If the trampoline and enclosure are to be moved a short distance, they should be moved by two persons, kept horizontal, and lifted slightly. If the trampoline and enclosure are to be moved a long distance, they should first be disassembled. See DISASSEMBLY on page 11. In addition, see the trampoline manufacturer's user's manual.

# EXPLODED DRAWING AND PART LIST

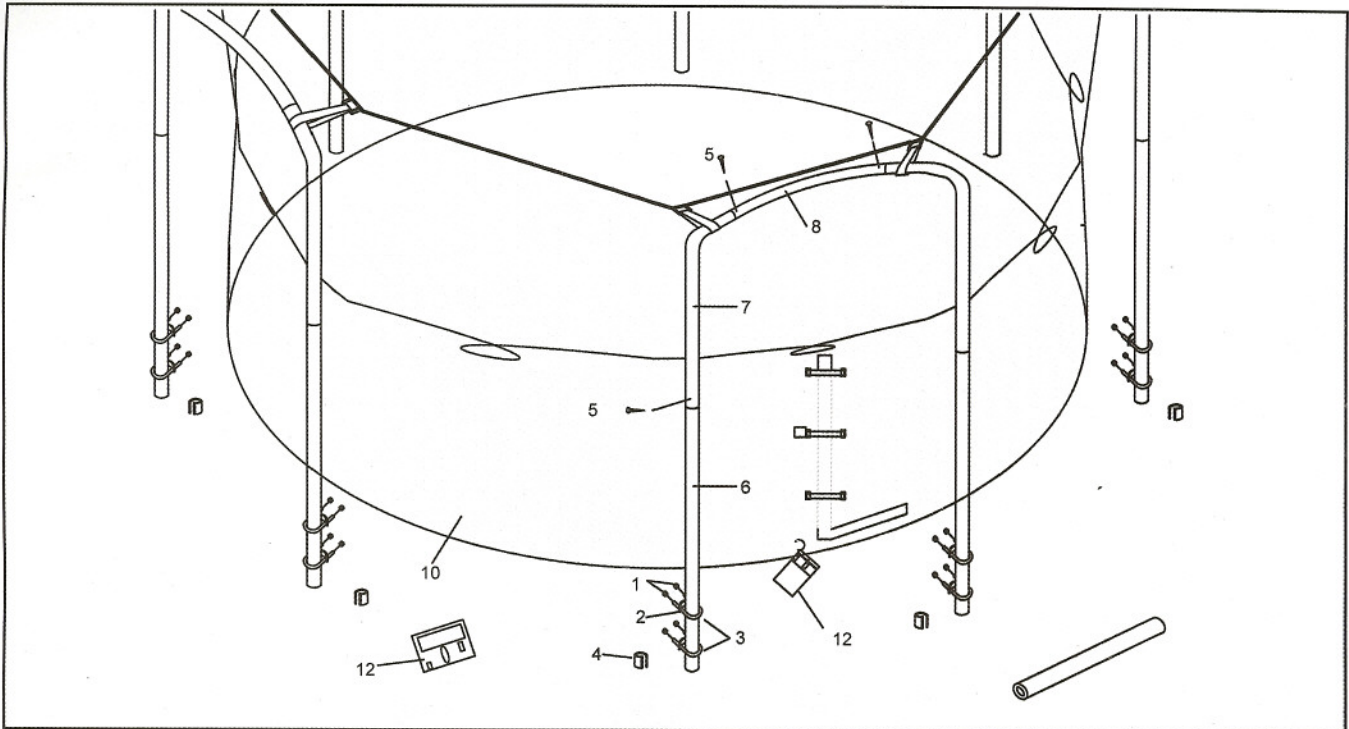

Key No.	Qty.	Description	Key No.	Qty.	Description
1	16	Locknut	10	1	Netting with attached Hardware
2	16	U-bolts Bracket	11*	16	Plastic cap
3	16	U-bolts	12	1	User's Manual and Safety Placard
4	8	Black C-clip	13*	8	Cord
5	16	Self-tapping Screw	14*	10	Plastic Needle (your enclosure may not need or include this part)
6	8	Straight Tube			
7	8	L-tube			
8	4	Curved Tube			
9	20	Foam Sleeve			

\*These parts are not illustrated.  
Specifications are subject to change without notice.

## ORDERING REPLACEMENT PARTS

To order replacement parts, visit our Web site at [www.bazoongi.com](http://www.bazoongi.com) or call our toll-free Customer Hot Line at 1-877-927-8777, Monday through Friday, 8 a.m. until 5 p.m. Central Time (excluding holidays). To help us assist you, please provide the following information when calling:

- the MODEL of the trampoline enclosure
- the NAME of the product (Bazoongi Enclosure)
- the KEY NUMBER and DESCRIPTION of the part (see the PART LIST above)
- the quantity needed
- the desired method of shipping