

# JUMP KING<sup>®</sup>

## Trampolines

### User Guide

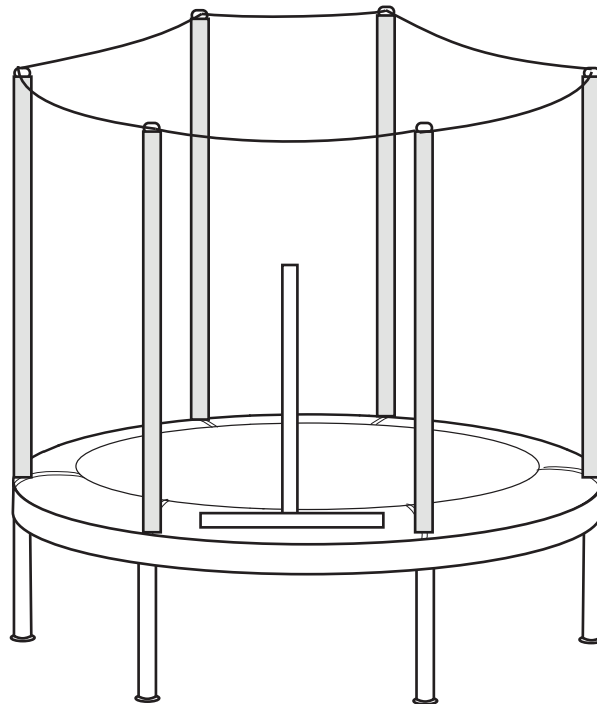

## 60in Trampoline & Enclosure

### Model: JK60R

The trampoline / enclosure is designed for users weighing 50kg (110lbs) or less.

**Got a Problem building your trampoline?**  
Please contact us at [contact@jumpking.com](mailto:contact@jumpking.com)



**WARNING:** Read these assembly instructions carefully before attempting to assemble or use this product. Keep this user guide in a safe place for future reference.



# JUMPKING®

## 60in Trampoline & Enclosure

### Model: JK60R

#### QUESTIONS?

If you have questions after reading this manual, please email us at [contact@jumpking.com](mailto:contact@jumpking.com). The trained technicians will provide immediate assistance.

#### REPLACEMENT PARTS

To order replacement parts, please visit our website at [www.jumpking.com](http://www.jumpking.com).

More detailed instructions on assembling their trampoline may be available on [www.jumpking.com](http://www.jumpking.com) in the Manual and Assembly section.

#### CONTENTS

IMPORTANT PRECAUTIONS .....	4
PART LIST .....	6
ASSEMBLY .....	7
CARE AND MAINTENANCE .....	14

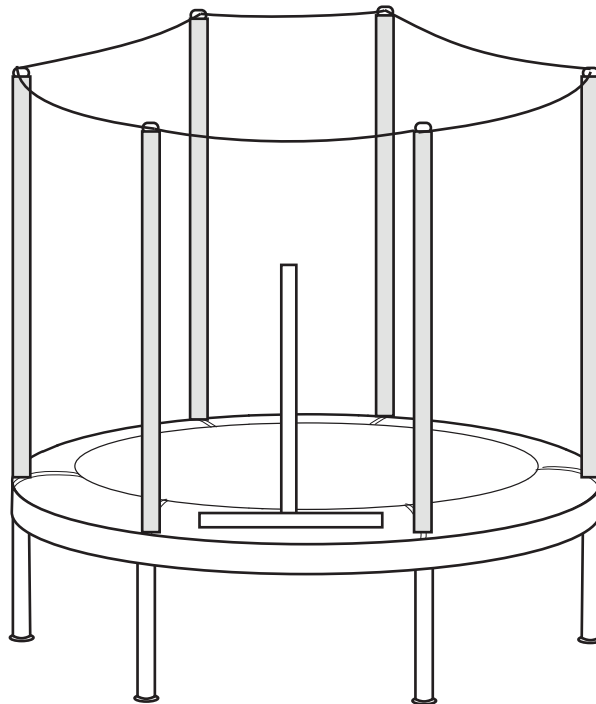

---

## IMPORTANT PRECAUTIONS

**⚠ WARNING:** To reduce the risk of serious injury, read and follow all warnings, precautions, and instructions in this manual before assembling and using the trampoline.

This product is intended for use by children above 3 years of age.

This enclosure is to be used only in connection with this trampoline.

Read and follow all warnings and instruction.

This product is intended to be assembled by an adult.

Maximum weight limited 50 kg / 110 lbs.

Warning! Not suitable for children under 36 months. Small parts and long cords may be a choking and stragunation hazard.

## BUILDING YOUR TRAMPOLINE

1. This is a 2 person build.
2. Time for build is approximately 2 hours.
3. Choose a good location:
  - On a level surface that is soft (*wood chippings, sand or grass*).
  - Ensure adequate overhead clearance. A minimum of 24ft (7.3m) from ground level, away from wires, trees and other possible hazards.
  - Ensure a clear space of 8.2ft (2.5m) around sides, away from walls, fences, structures, roads and other hard surfaces and play areas.

## WHAT YOU WILL NEED

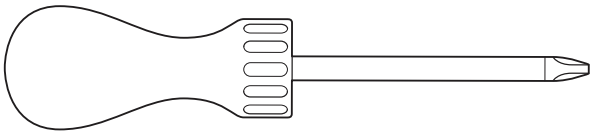

Description:  
**Cross-head screwdriver**

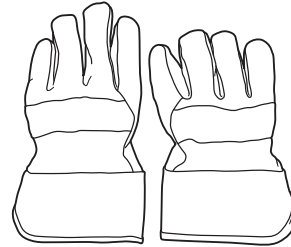

Description:  
**Gloves**

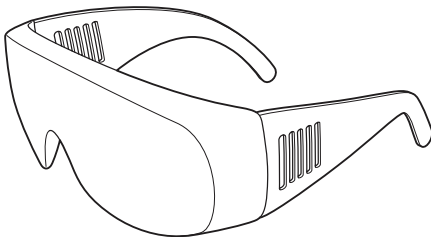



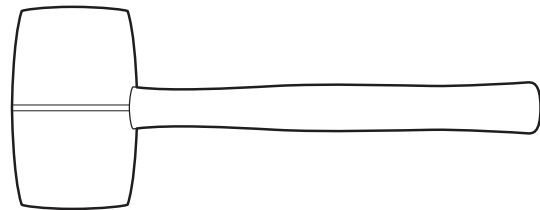



Description:  
**Safety glasses**

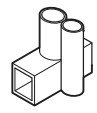

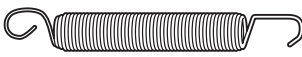
Description:  
**Mallet**

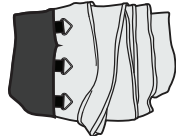
# PARTS LIST

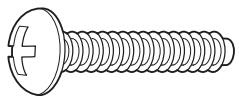
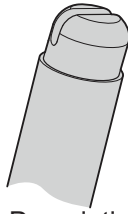
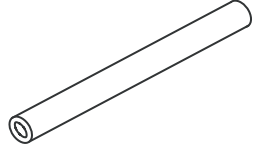
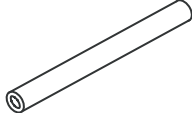
<p>Part <b>A</b></p>  <p>Description: <b>Top Tube</b> JK60R-TR Quantity: <b>6</b></p>	<p>Part <b>B</b></p>  <p>Description: <b>T-Connector</b> JK60R-TCWS Quantity: <b>6</b></p>	<p>Part <b>C</b></p>  <p>Description: <b>Straight Leg with foam sleeve</b> JK60R-LEG Quantity: <b>6</b></p>	<p>Part <b>D</b></p>  <p>Description: <b>Plastic foot cap</b> JK60R-FC Quantity: <b>6</b></p>
<p>Part <b>E</b></p>  <p>Description: <b>Springs</b> SP3.5 Quantity: <b>30</b></p>	<p>Part <b>F</b></p>  <p>Description: <b>Spring tool</b> HWSPT Quantity: <b>1</b></p>	<p>Part <b>G</b></p>  <p>Description: <b>Jumping bed / Pad / Enclosure mesh</b> BED60R-BNP Quantity: <b>1</b></p>	<p>Part <b>H</b></p>  <p>Description: <b>Top enclosure poles</b> JK60R-ETP Quantity: <b>6</b></p>
<p>Part <b>I</b></p>  <p>Description: <b>Bottom enclosure poles</b> JK60R-EBP Quantity: <b>6</b></p>	<p>Part <b>J</b></p>  <p>Description: <b>Self tapping screws</b> HWSTS Quantity: <b>20</b> Included 2 pcs for spare use.</p>	<p>Part <b>K</b></p>  <p>Description: <b>Caps for enclosure pole</b> HWEPC10.5-25 Quantity: <b>6</b></p>	<p>Part <b>L</b></p>  <p>Description: <b>Enclosure foam sleeve</b> (Has been attached to the Top &amp; Bottom enclosure poles) FSBLK44 Quantity: <b>12</b></p>
<p>Part <b>M</b></p>  <p>Description: <b>Leg foam sleeve</b>  JK60R-FL Quantity: <b>6</b></p>			

# STEP 1 : ASSEMBLING THE FRAME

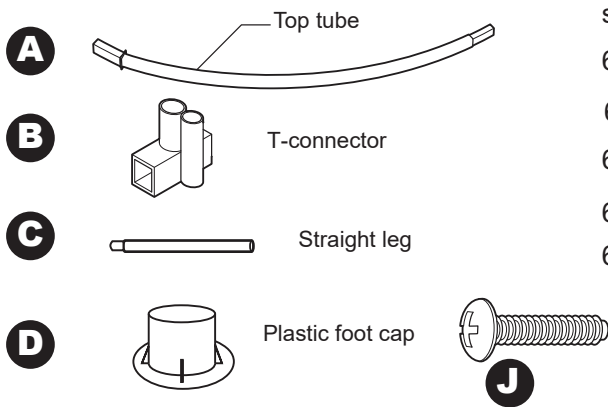

You will need the following parts to complete section 1:

6 x Top Tube - **Part A**

6 x T-connector - **Part B**

6 x Straight leg - **Part C**

6 x Plastic foot cap - **Part D**

6 x Self-tapping screw - **Part J**

You will also need a cross-head screwdriver (*not supplied*).

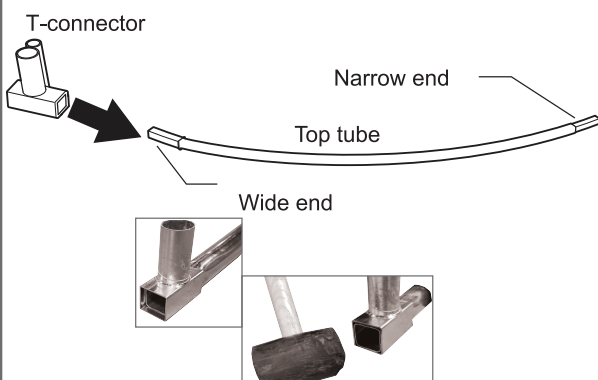
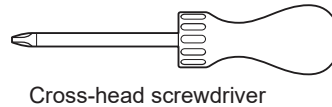

**Notice:** Must wear gloves and protective eyewear during assembly.

First, layout the 6 pieces of top tube. Please note there is a Wide end and a Narrow end on Top tube. Insert the T-connector to the Top tube with Wide end. Complete the remaining 6 pieces Top tube.

Note: Use mallet to ensure connectors are fully assembled to the top rail, if needed.

Make sure the Small round tubes on T-connectors are facing inside.

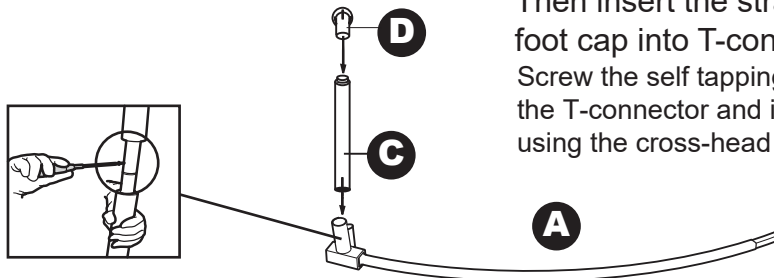

Then insert the straight leg and plastic foot cap into T-connector.

Screw the self tapping screws through the slot in the T-connector and into the hole in the leg tube using the cross-head screwdriver.

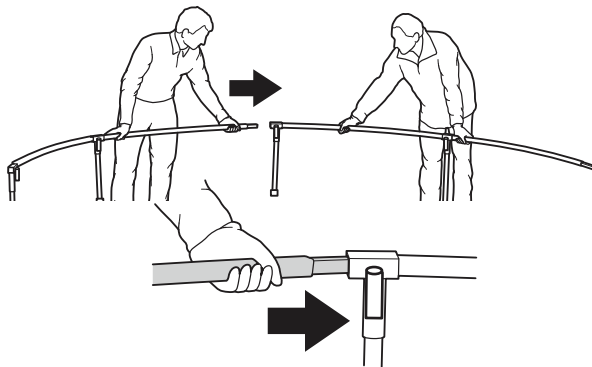

**This step will require 2 people who must be wearing gloves.**

Slot two of the frame sections together as shown in the diagram.

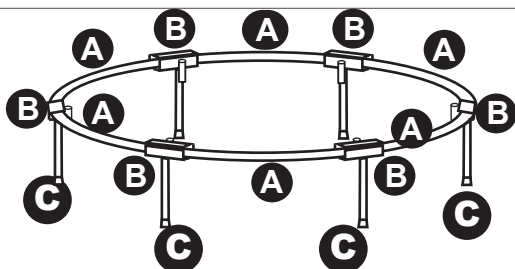

**Important:** Ensure all of the top tubes and straight legs are fully inserted.

The frame is now fully assembled and you have now completed step 1.

## STEP 2 : FITTING THE SEWING PART

This step will require 2 people who must be wearing gloves and protective eye wear.

Lay the jumping bed / pad / enclosure mesh Part G out inside the frame of the trampoline

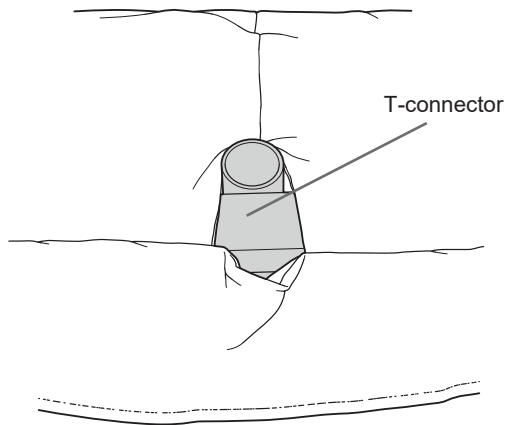
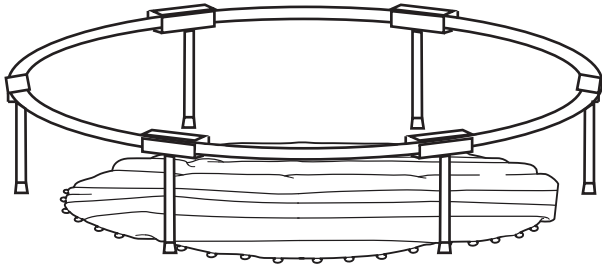

Align the openings in the frame pad with the T-connector on the frame.

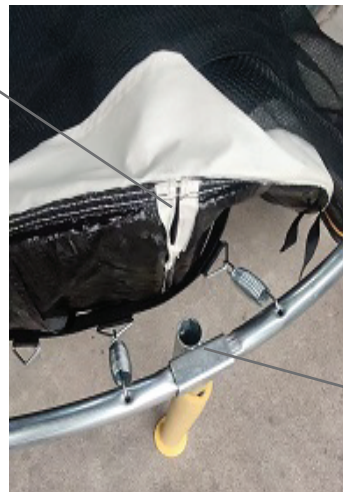
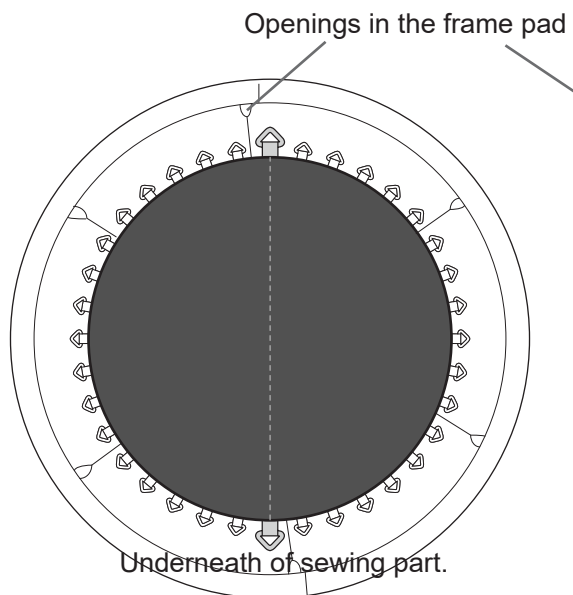

Locate the 2 V-rings beside of opening in the frame pad. These will be at 180° to each other.

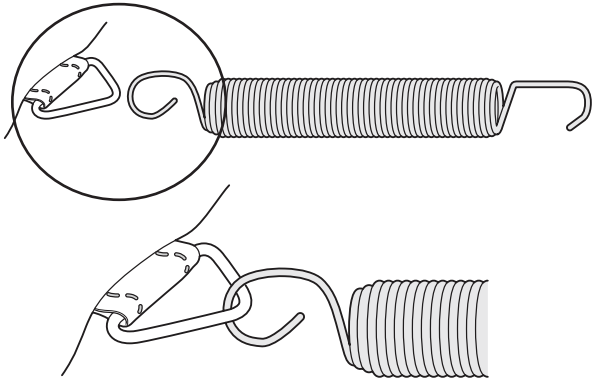

Slot one of the springs **part F** onto one of the webbing V-Rings as shown.

Important: springs must be slotted the correct way around.

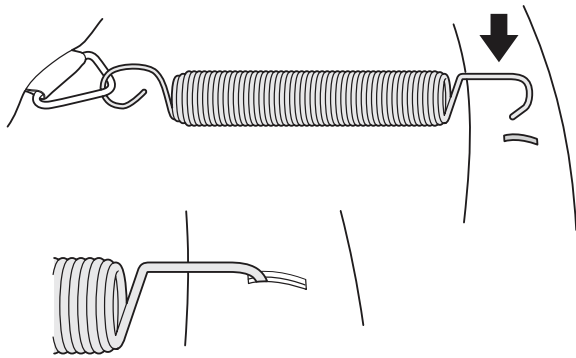

Slot the other end of the spring into one of the spring slots in the top of the frame.

**IMPORTANT: Ensure the spring is fully inserted into the slot on the top of the frame.**

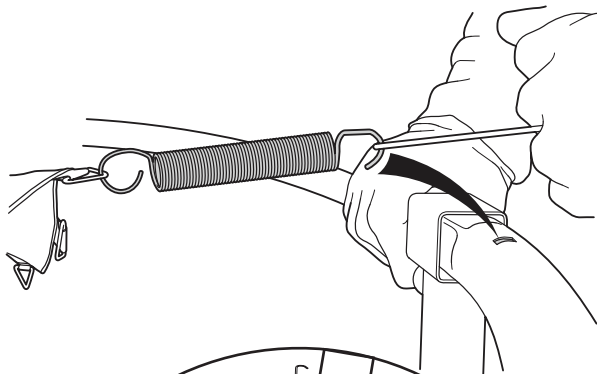

Attach a spring to the opposite of V-ring.

**Important:** You will now need to use the spring tool **part G** to attach the spring to the frame.

Hook the spring tool onto end of spring, and pull until the spring can be slotted into the spring slot on the top of the frame.

**IMPORTANT: Ensure the spring is fully inserted into the slot on the frame.**

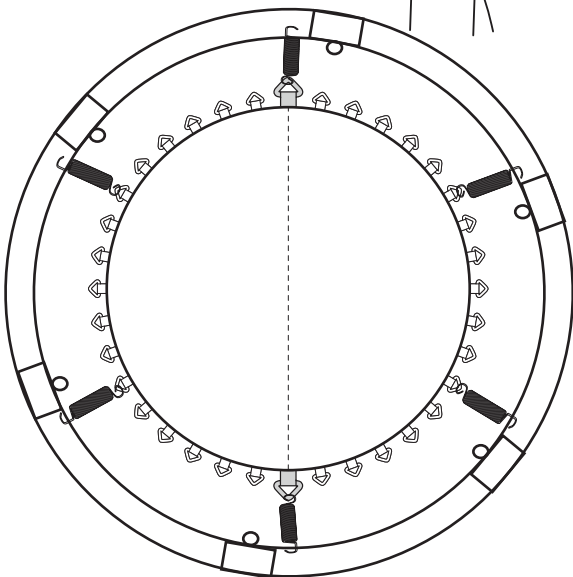

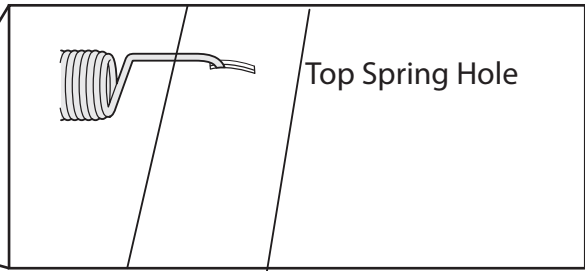
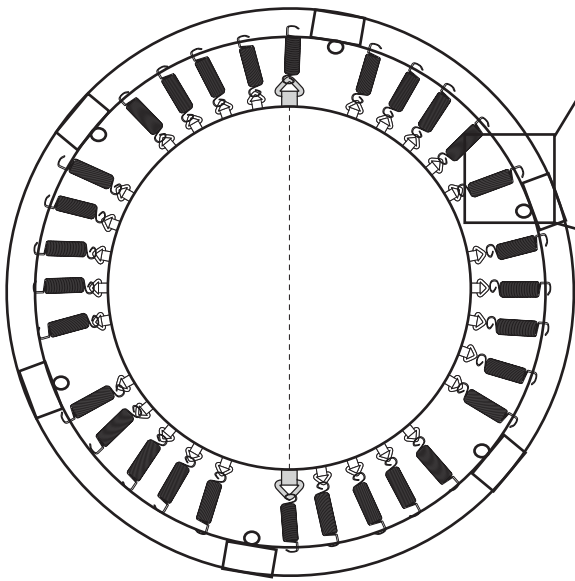

Continue to attach springs in the same sequence as above: in the middle of each section, making sure the next spring is attached on the opposite side to even out the tension.

**Important:** The stitched bed is designed like elastic to be bouncy, which means that during construction it may look like it won't fit. Please note that it will stretch to the correct size when attaching the springs, this may take some force.

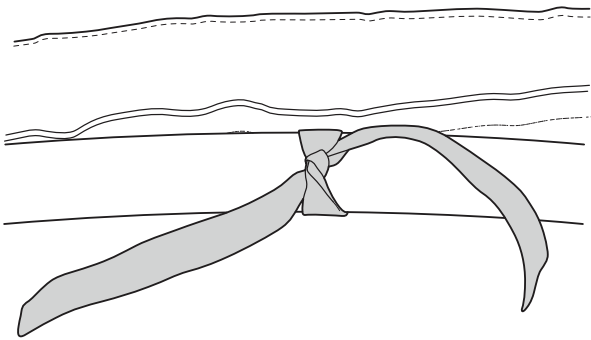

Tie the outer elastic straps on the underside of the frame pad around the top tubes of the frame.

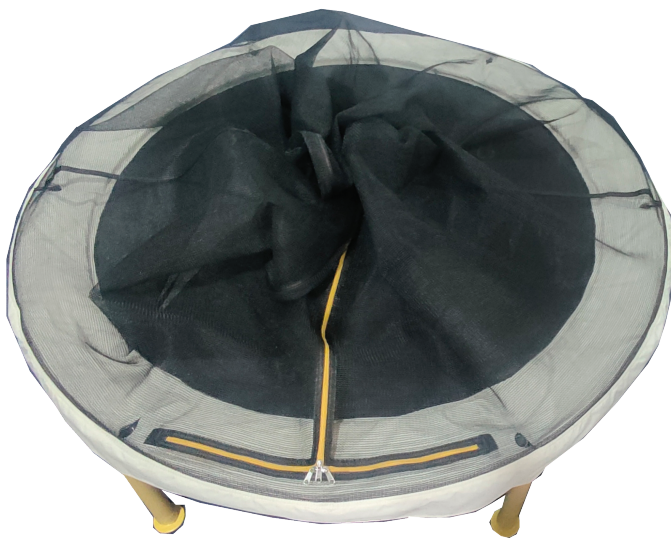

## STEP 3: FITTING THE ENCLOSURE TUBES

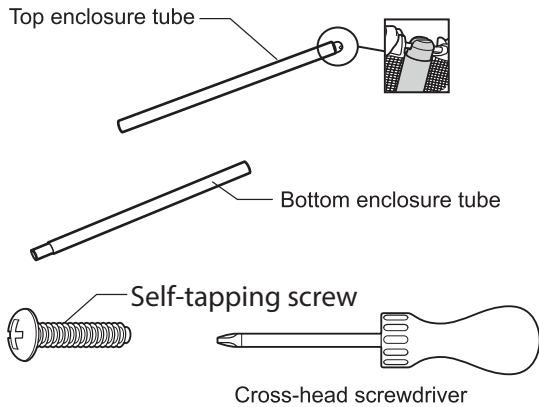

You will need the following parts to complete step 3:

6 x Top enclosure tube - Part H

6 x Bottom enclosure tube - Part I

6 x Self-tapping screw - Part J

You will also need a cross-head screwdriver (*not supplied*).

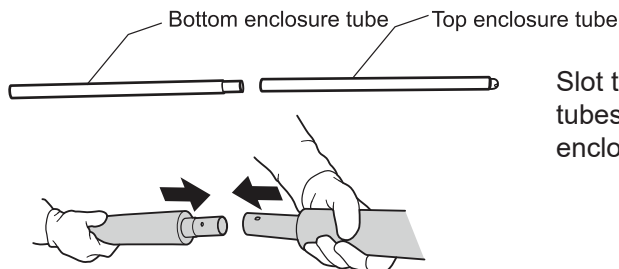

Slot the thin end of one of the bottom enclosure tubes into the open end of one of the top enclosure tubes.

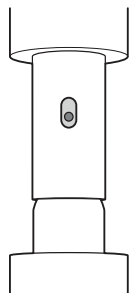

Align the hole in the bottom enclosure tube with the slot in the top enclosure tube.

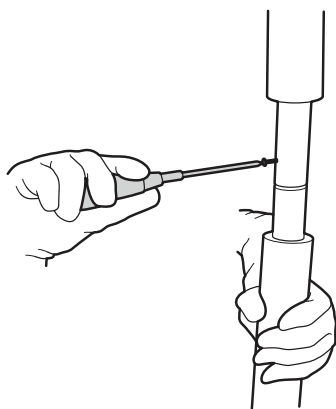

Screw one of the self tapping screws through the slot in the top enclosure tube and into the hole in the bottom enclosure tube using the cross-head screwdriver.

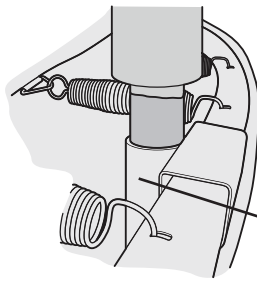

Slot the bottom enclosure tube into the tubes in the T-connector visible through the slots in the frame pad.

Screw the self tapping screws through the slot in the T-connector and into the hole in the bottom of enclosure tube using the cross-head screwdriver.

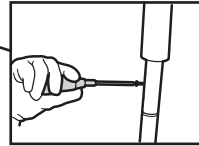

Slot the four enclosure tubes with hemisphere caps into the T-connector on the frame (inside the enclosure mesh).

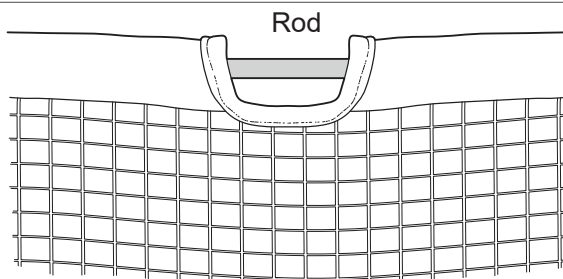

Find the ROD on top of enclosure netting.

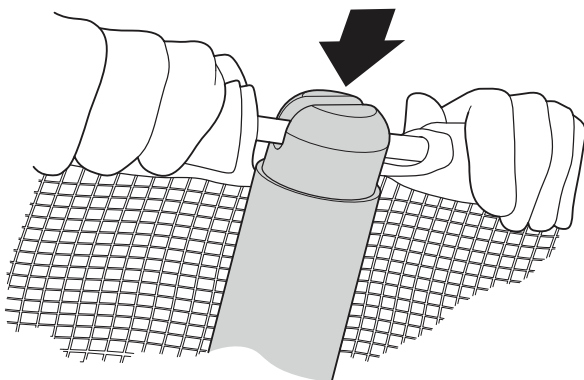

Insert one of the exposed sections of the rod into a plastic hemisphere cap on top of one of the enclosure tubes.



Attach the four exposed sections of the rods to the other enclosure tubes in the order shown in the diagram.

Note: Please make sure the zipper is open for easy set up.



Slot the remaining two enclosure tubes with hemisphere caps into the T-connector on the frame (inside the enclosure mesh).

Then insert the remaining rod into hemisphere cap.



Now you can zip up the bottom zipper then vertical zipper.



The enclosure net is now fitted and you have completed step 3.

# CARE AND MAINTENANCE

## Care

Do not allow pets or animals on the trampoline or inside the enclosure, as claws may snag and pull the bed material or damage the frame pad or netting.

The trampoline/enclosure is intended to be used by one person at a time weighing 50kg(110lbs) or less. The user should be either barefoot or wearing socks.

Street shoes or tennis shoes should not be worn on the trampoline. The user should remove all sharp objects from his or her person that may cause injury or damage to the bed. Heavy, sharp, or pointed hard objects should not contact the bed.

## Maintenance

Your trampoline is manufactured using quality materials and crafted to provide your children with many years of enjoyment. Proper maintenance and care will help to prolong the life of the trampoline and reduce the possibility of injury.

Prolonged exposure to the sun, will shorten the life of the trampoline/enclosure fabric. For longer fabric life store the trampoline/enclosure when it is not being used. A dry trampoline/enclosure, properly stored, will provide the longest life of the fabric, sewing, and hardware. Remove the enclosure from the trampoline during harsh weather conditions or during long periods of non-use.

The following guidelines should always be observed. Inspect the trampoline/enclosure before each use, and replace any worn, damaged, or missing parts. The following conditions could represent potential hazards and increase the chance of personal injury:

- a missing, improperly positioned, or insecurely attached frame pad, netting, enclosure tubes, foam

sleeves.

- punctures, frays, tears, or holes worn in the bed, frame pad, netting, foam sleeves.

- deterioration in the stitching or fabric of the bed, frame pad, netting.

- broken or missing springs.

- a bent or broken frame, leg, enclosure poles.

- a sagging bed or netting.

- sharp protrusions on the frame, suspension system, enclosure tubes.

If any of these conditions exist, the trampoline should be disassembled or otherwise protected against use until the condition is corrected.

## Removing and storing the trampoline/enclosure

Make sure that the trampoline/enclosure is dry before removing and storing it. Use caution while removing the tubes due to the weight of the tubes.

Once the enclosure is removed from the trampoline, remove all items from the trampoline bed. Make sure that the bed is clean and that it has no tears or holes. Store the trampoline/enclosure in a safe, dry location.

## Moving the trampoline

If the trampoline/enclosure needs to be moved, it should be moved by two persons, kept horizontal, and lifted slightly. If necessary, the trampoline/enclosure can be disassembled for moving.

To disassemble the trampoline/enclosure, follow the assembly steps in reverse order (see pages 7 to 18). Do not attempt to disassemble the frame sections, legs or bases before the bed and springs have been removed.